



G A T E W A Y

A NEW LIFE IN THE NEW CITY.

Welcome to a stunning new life in a spectacular new city. The place to be is J Gateway, the first and possibly the only designated full residential development in the whole of Jurong Gateway – that, together with the Lakeside Precinct, forms the 360ha Jurong Lake District. Get ready to grasp all the shining new opportunities at the new Central Business District of the West. Own privileged access to the biggest regional centre, surrounding Jurong East MRT Station. This is a unique location that tears down the boundaries between live, work and play.



- International Business Park
- Future Office Cluster
- Jurong Country Club
- JTC Summit
- Big Box
- Future Hotel Cluster
- JCube
- Future Lakeside Village
- JEM
- Jurong East MRT Station (Interchange)
- Westgate
- Promenades & Boardwalks

LAKESIDE
Precinct

JURONG
GATEWAY
Precinct

ACT

1

ENJOY INTEGRATED CONNECTIONS
AT THE NEW TRANSPORT HUB.

MRT

BUS INTERCHANGE

EXPRESSWAY

BUSTLING, BUZZING, BLOOMING. THIS IS CITY LIVING EVOLVED.

All the right connections are at J Gateway. You are just steps away from Jurong East MRT Station – the interchange for the North-South and East-West MRT Lines – linking the upcoming Jurong Region MRT Line and giving swift access to every part of Singapore. The station will be fully integrated with a bus interchange and future commercial developments.

Be connected to major arterial roads and expressways such as Boon Lay Way, PIE and AYE that make it a breeze to get to Orchard Road, the CBD, the Marina area, NTU and NUS.

Enjoy seamless pedestrian connections, including new covered overhead bridges and link ways leading to other developments in Jurong Gateway. Elevated boardwalks and park connectors also lead you to picturesque new parks and promenades in the upcoming Lakeside Village.

right next to

- Jurong East MRT Station
- Future Integrated Transport Hub
- Westgate
- JEM
- Ng Teng Fong General Hospital

8 minutes' walk to

- JCube
- IMM Building
- Jurong Regional Library
- Big Box

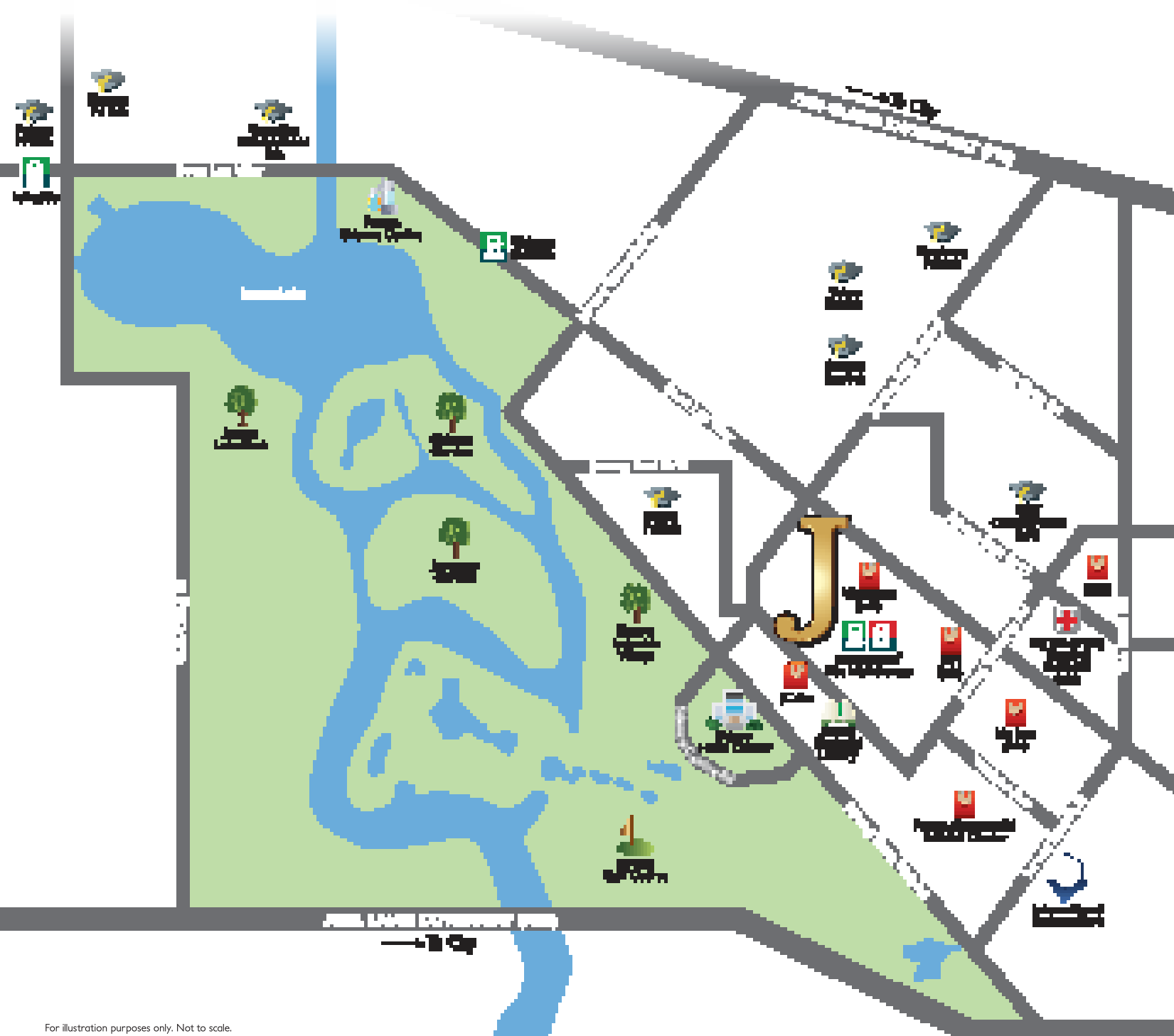
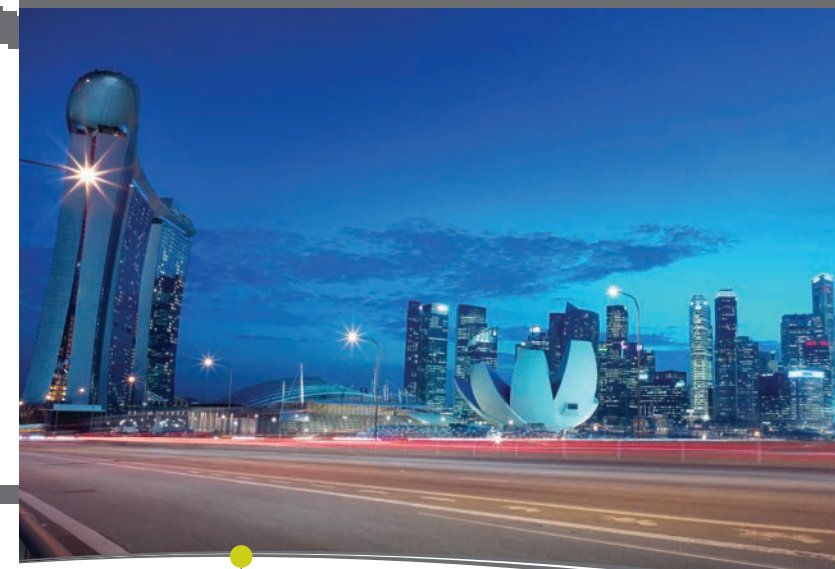
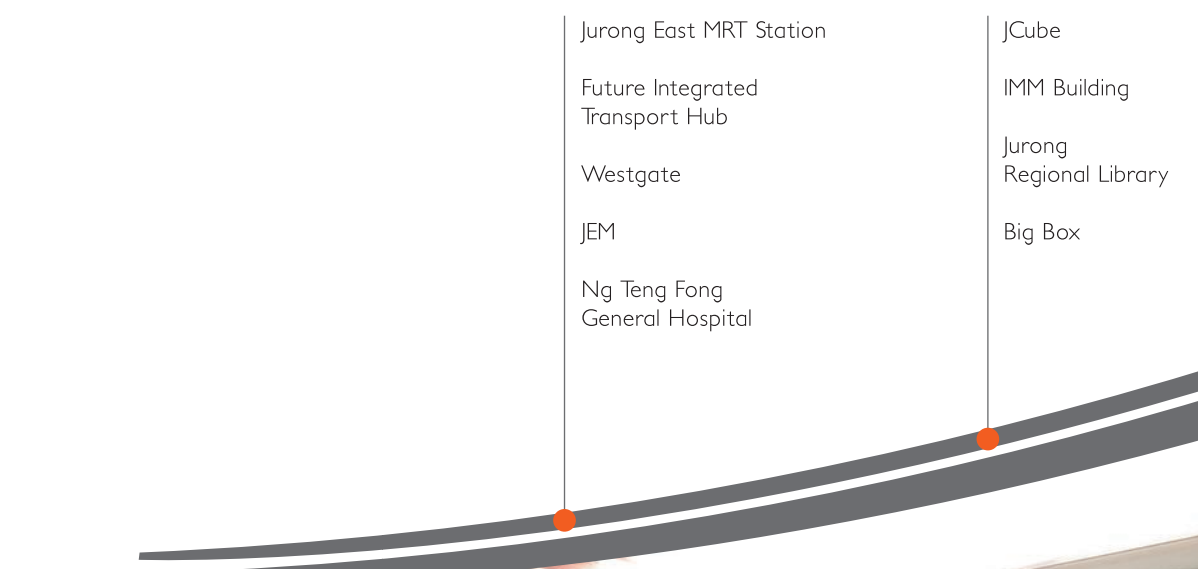

5 minutes' drive to

- International Business Park
- PIE
- AYE
- Jurong Golf Course
- Canadian International School
- Japanese Garden
- Chinese Garden

10 minutes' drive to

- NUS
- NTU
- Ngee Ann Polytechnic
- Singapore Polytechnic

18 minutes' drive to

- CBD
- Orchard Road

ACT



LIVING IT UP
AT YOUR DOORSTEP.

ACTIVITIES AND AMENITIES AT YOUR FINGERTIPS. DISCOVER INTEGRATED LIVING.

Sensational activities await at Westgate, JEM, Big Box, IMM, and JCube with its cineplex, Singapore's first Olympic size ice-skating rink, and the first IMAX theatre outside the city area. With about 250,000 sq m of shopping, dining and entertainment, everything you need is all around.

Reap the rewards of your position and vicinity to the International Business Park with MNCs like Dell, Sony and Acer. Approximately 500,000 sq m of future office space and hospitals will spur strong job creation – drawing both locals and foreigners, and ensuring residential rental demand, high capital values and investment potential.

Your location is full of excitement – linked via elevated landscaped deck to Jurong Lakeside, a major leisure destination for local and international visitors. Exhilarating highlights include the new Science Centre, waterfront park and promenade with water activities like kayaking and dragon boating, and edutainment attractions. A new waterway will also bring closer Jurong Lake, and the upcoming Lakeside Village with shopping, dining, entertainment and boutique hotels.





ACT

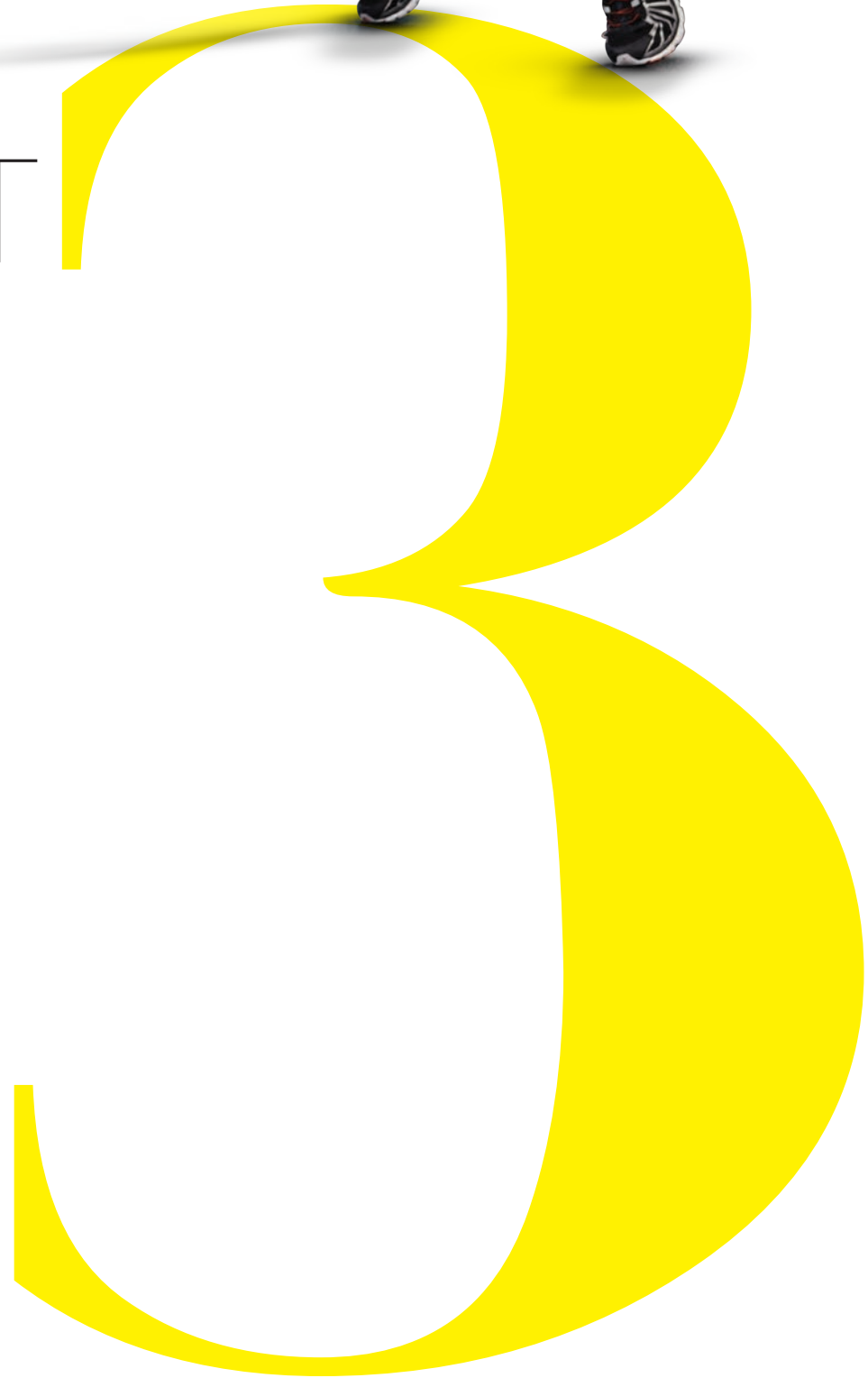

ENGAGE AND INDULGE.
IT'S A WHOLE NEW LIFESTYLE.

YOUR PLACE OF PRIDE.

Take your place of pride in the Jurong skyline, at Singapore's next architectural icon. Live out your dreams in astonishing asymmetric towers rising over the surrounding landscape – an outstanding statement of metropolitan living. Two towers of 21 and 39 storeys, 738 units, one stunning exemplar of modern design. Within its sleek, sculpted form, a stunning selection of 1, 2, 3, and 4-bedroom units and penthouses await, designed to offer all the indulgences of the contemporary lifestyle.



1st STOREY



LEGEND

- A. RONDURE CLUBHOUSE
- B. SUN DECK
- C. LIFT ISLAND
- D. CLUBHOUSE PARTY DECK
- E. LEISURE POOL
- F. JACUZZI LOUNGE
- G. CHAMPAGNE SPARKLES
- H. POOL PROMENADE
- I. STAR GALLERY
- J. REFLECTIVE POND
- K. WADING POOL DECK
- L. DIAMOND CABANA
- M. 50M INFINITY EDGE LAP POOL
- N. PRIVATE DINING PAVILION
- O. PARTY POOL WITH JACUZZI
- P. MEANDERING PATH
- Q. BBQ PAVILION
- R. KID'S PLAY POOL
- S. VERTICAL PLAYGROUND
- T. "CLUB" PARTY DECK
- U. CHILL-OUT LOUNGE
- V. SIDE GATE

Artist's Impression

IMMERSE IN INDULGENCE.

Make a new record at the 50m Infinity Edge Lap Pool, and make a splash at the Leisure Pool. Let your little ones have an adventure at the Kid's Play Pool with Vertical Playground. Entertain in Cafe del Mar style at the Rondure Clubhouse, or the Private Dining Pavilion and attached Party Pool with Jacuzzi. Or simply chill-out at the poolside Diamond Cabana and watch the world go by.



INTO A WORLD OF EXPERIENCES.

Get into the zone and hit your fitness goals, at the Diamond Gym Capsule, which will block out all distractions and transport you into a focused state of mind and body. Or get into gear and slip into the Outdoor Fitness and Indoor Gym for workouts accompanied by panoramic views of either the Jurong Lake District or Bukit Timah Hill. The Garden Dining Box provides an enchanting setting for romantic dinners and intimate conversations, the Hanging Cocoon lets you rest and relax amidst verdant greenery, and the Reading Corner is the perfect place to delve into a fine tale.



24th STOREY SKY GARDEN

LEGEND

- | | |
|----------------------|------------------------|
| A. GOURMET COUNTER | F. INDOOR GYM |
| B. GARDEN DINING BOX | G. DIAMOND GYM CAPSULE |
| C. READING CORNER | H. CHILL-OUT LOUNGE |
| D. LANDSCAPE GARDEN | I. HANGING COCOON |
| E. OUTDOOR FITNESS | |

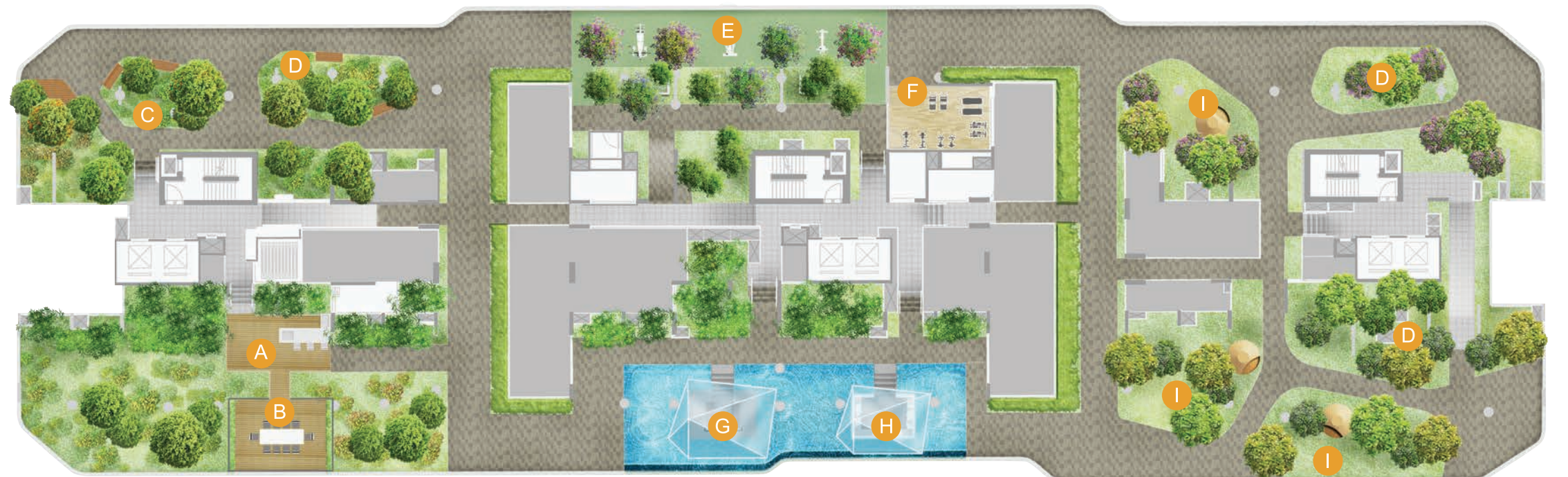

GET CONNECTED WITH
LEISURE AND PLEASURE.

21st STOREY

FACILITIES

- A. TENNIS COURT
- B. CONFERENCE ROOM

Own the excitement and activity that extends throughout, take for instance the Tennis Court and Conference Room on the rooftop of the SOHO concept tower, taking matchups to a whole new level.



Connect with your self, and connect with others, at unique landscaped sky gardens that also connect the residential towers to one another on every level. Where the green of nature meets the blue of the sky, contemplation meets community, and both are brought to higher levels.

35th STOREY SKY TERRACE

Party into the night on the swank roof garden on the 35th floor Sky Terrace, grab a drink from the J Bar and take a breather on the Chill-Out Lounge, or cook up a storm for your loved ones at the BBQ Area.

LEGEND

- A. J BAR
- B. CHILL-OUT LOUNGE
- C. BBQ AREA
- D. AL FRESCO DINING
- E. PRIVATE CABANA



ACT

4



STEP UP TO SCINTILLATING LIVING.

SOHO-INSPIRED

STYLISH AND DYNAMIC LIVING.

Take ownership of stylish and flexible spaces that can be tailored for your lifestyle. Fulfill your needs with the world of possibilities that opens up with the SOHO-inspired units' high ceilings and loft platforms. A privileged few will have the luxury of facing Sky Patios that bring in charming views of greenery into your living space.



SOHO-INSPIRED

1 BEDROOM

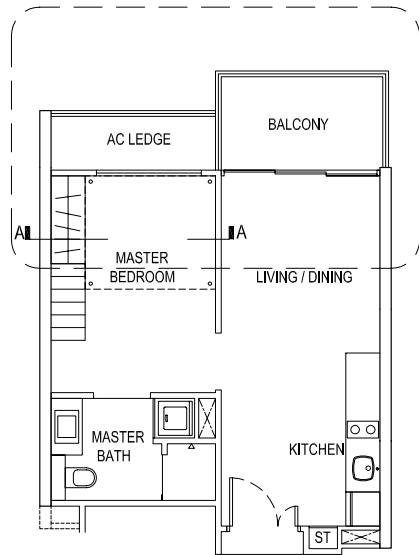

TYPE SA1

46 sq m / 495 sq ft
#02-24 to #20-24
#02-25 to #20-25

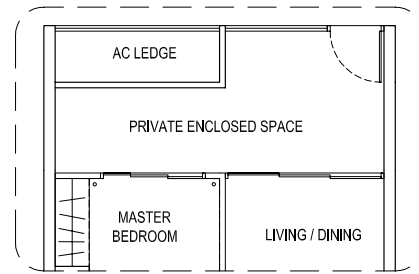

TYPE SA1-P

53 sq m / 571 sq ft (including PES of 12 sq m / 129 sq ft)
#01-24, #01-25

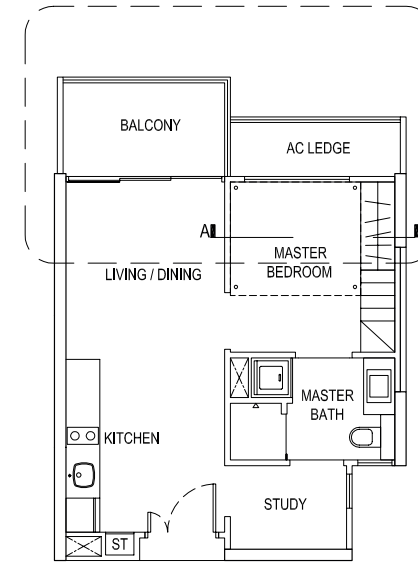

TYPE SA3

47 sq m / 506 sq ft
#02-26 to #20-26

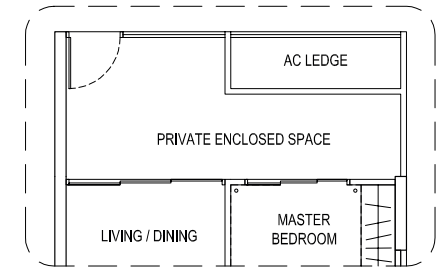

TYPE SA3-P

54 sq m / 581 sq ft (including PES of 12 sq m / 129 sq ft)
#01-26

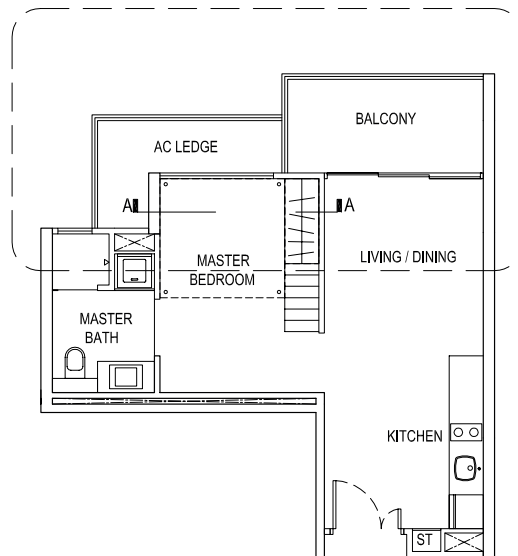

TYPE SA2

49 sq m / 527 sq ft
#02-16 to #20-16

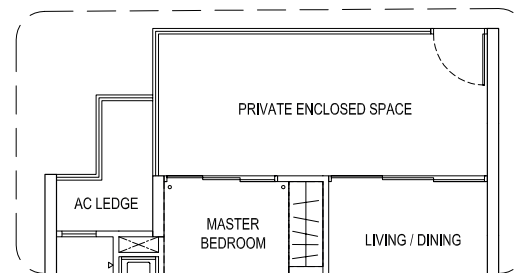

TYPE SA2-P

56 sq m / 603 sq ft (including PES of 15 sq m / 161 sq ft)
#01-16

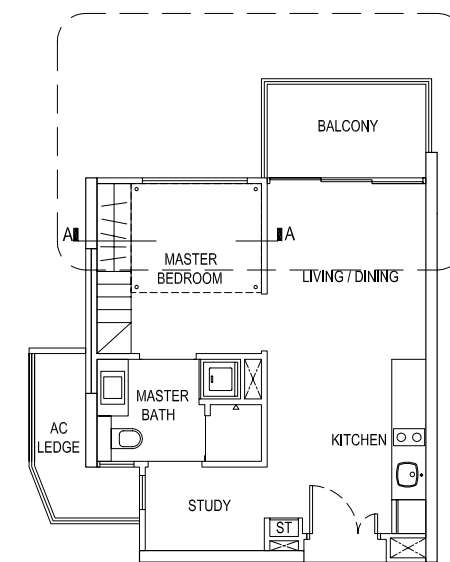

TYPE SA4

48 sq m / 517 sq ft
#02-23 to #20-23

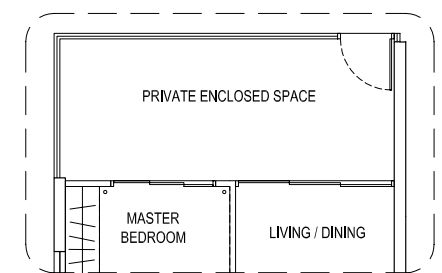

TYPE SA4-P

58 sq m / 624 sq ft (including PES of 15 sq m / 161 sq ft)
#01-23

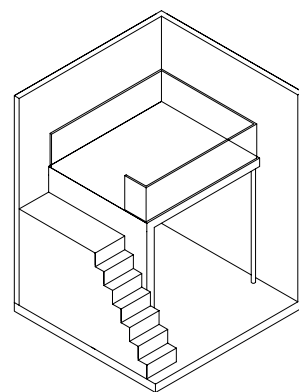
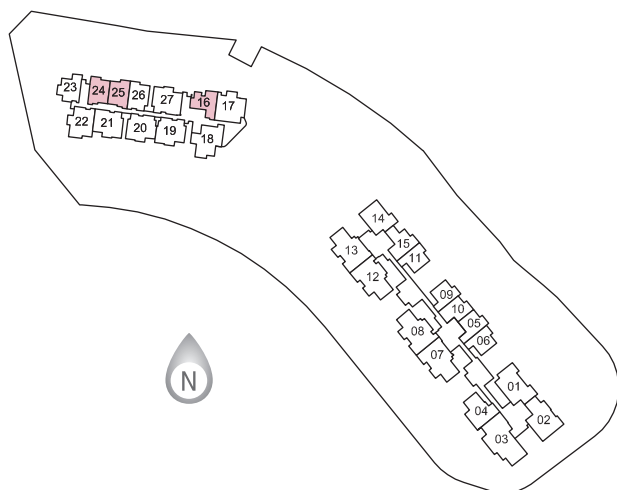

ISOMETRIC VIEW OF PLATFORM
(MIRROR IMAGE FOR TYPE SA2)

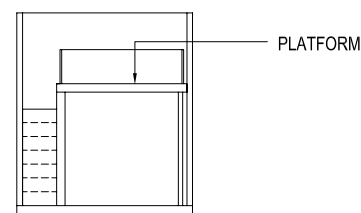

SECTION A-A (MIRROR IMAGE FOR TYPE SA2)
FLOOR TO FLOOR HEIGHT VARIES.
3.60M - 2ND, 3RD, 4TH, 6TH, 7TH, 9TH, 10TH, 12TH,
13TH, 15TH, 16TH, 18TH, 19TH STOREY
3.85M - 5TH, 8TH, 11TH, 14TH, 17TH STOREY
4.00M - 1ST AND 20TH STOREY

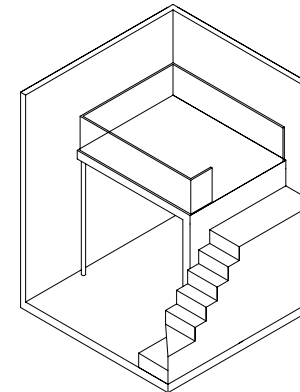

ISOMETRIC VIEW OF PLATFORM
(MIRROR IMAGE FOR TYPE SA4)

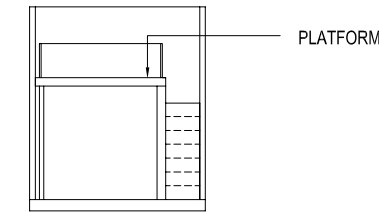

SECTION A-A (MIRROR IMAGE FOR TYPE SA4)
FLOOR TO FLOOR HEIGHT VARIES.
3.60M - 2ND, 3RD, 4TH, 6TH, 7TH, 9TH, 10TH, 12TH,
13TH, 15TH, 16TH, 18TH, 19TH STOREY
3.85M - 5TH, 8TH, 11TH, 14TH, 17TH STOREY
4.00M - 1ST AND 20TH STOREY



SOHO-INSPIRED

1 BEDROOM + STUDY

SOHO-INSPIRED

2 BEDROOM

SOHO-INSPIRED

2 BEDROOM

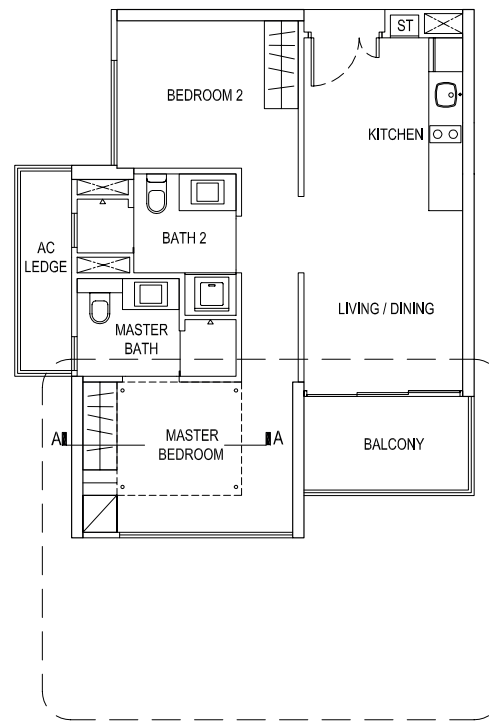

TYPE SB1
63 sq m / 678 sq ft
#02-22 to #20-22

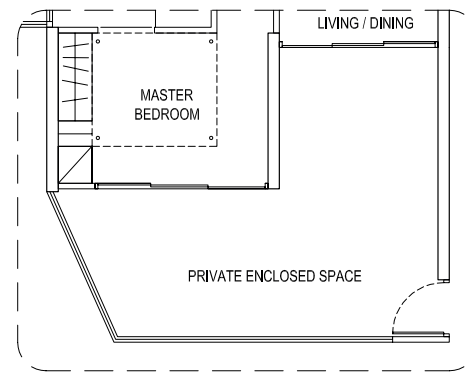

TYPE SB1-P
83 sq m / 893 sq ft (including PES of 25 sq m / 269 sq ft)
#01-22

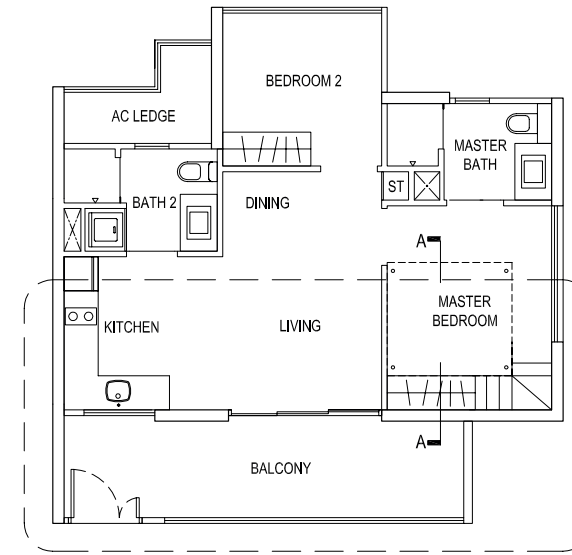

TYPE SB2
69 sq m / 743 sq ft
#02-17 to #20-17

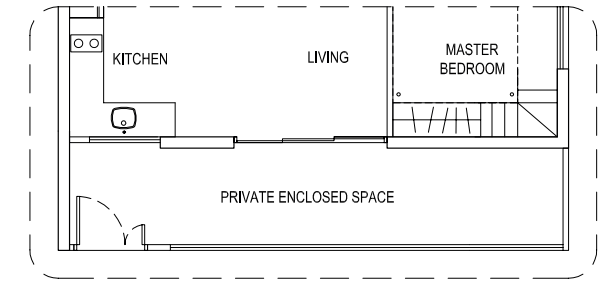

TYPE SB2-P
72 sq m / 775 sq ft (including PES of 17 sq m / 183 sq ft)
#01-17

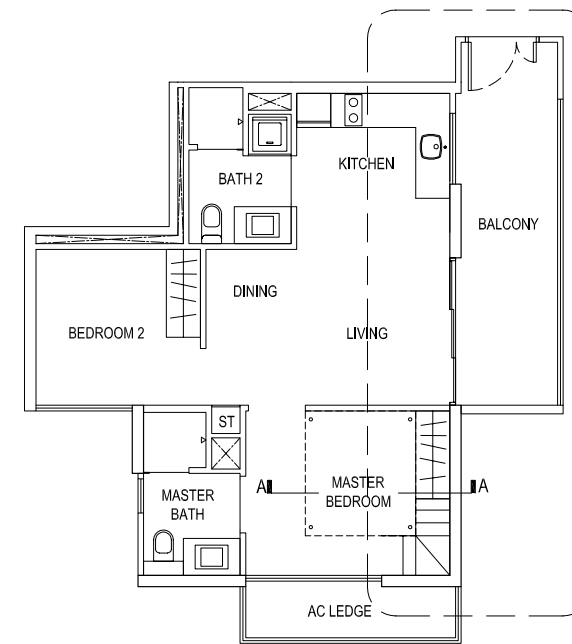

TYPE SB3
69 sq m / 743 sq ft
#02-18 to #20-18

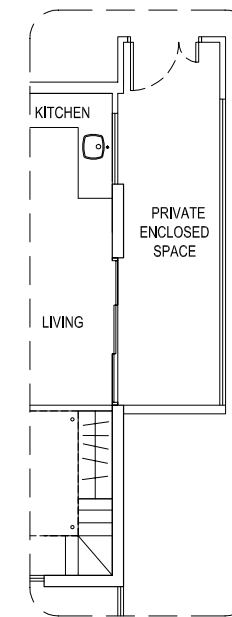

TYPE SB3-P
69 sq m / 743 sq ft (including PES of 13 sq m / 140 sq ft)
#01-18

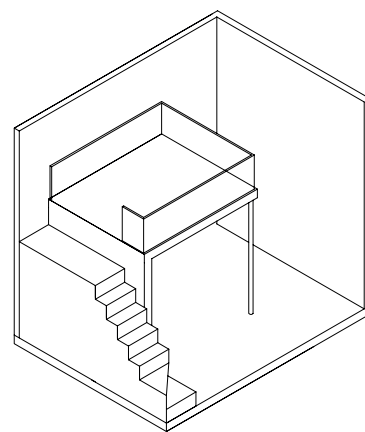

ISOMETRIC VIEW OF PLATFORM

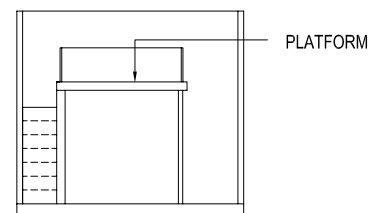

SECTION A-A
FLOOR TO FLOOR HEIGHT VARIES.
3.60M - 2ND, 3RD, 4TH, 6TH, 7TH, 9TH, 10TH, 12TH,
13TH, 15TH, 16TH, 18TH, 19TH STOREY
3.85M - 5TH, 8TH, 11TH, 14TH, 17TH STOREY
4.00M - 1ST AND 20TH STOREY

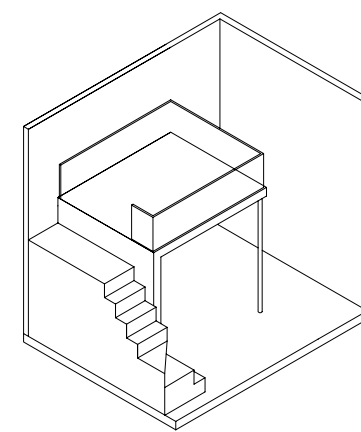

ISOMETRIC VIEW OF PLATFORM
(MIRROR IMAGE FOR SB3)

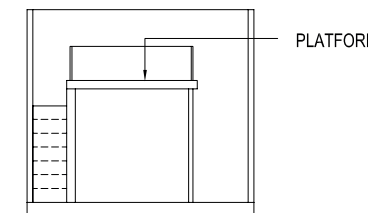

SECTION A-A (MIRROR IMAGE FOR SB3)
FLOOR TO FLOOR HEIGHT VARIES.
3.60M - 2ND, 3RD, 4TH, 6TH, 7TH, 9TH, 10TH, 12TH,
13TH, 15TH, 16TH, 18TH, 19TH STOREY
3.85M - 5TH, 8TH, 11TH, 14TH, 17TH STOREY
4.00M - 1ST AND 20TH STOREY

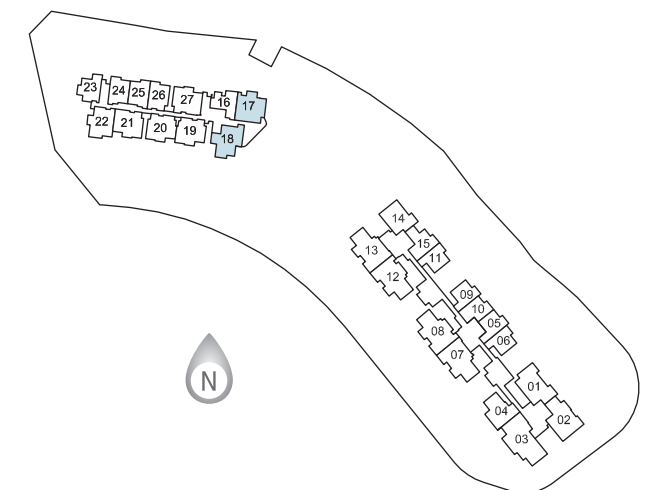

SOHO-INSPIRED

2 BEDROOM + STUDY

SOHO-INSPIRED

2 BEDROOM + STUDY

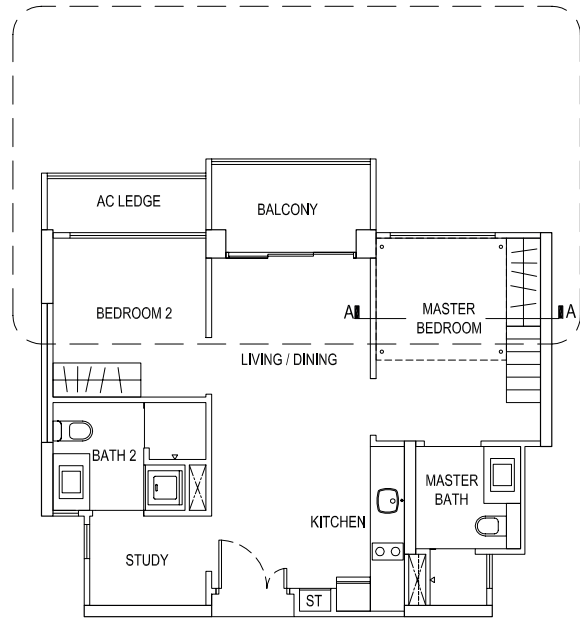

TYPE SB4
 63 sq m / 678 sq ft
 #02-20 to #20-20
 #02-21 to #20-21
 #02-27 to #20-27

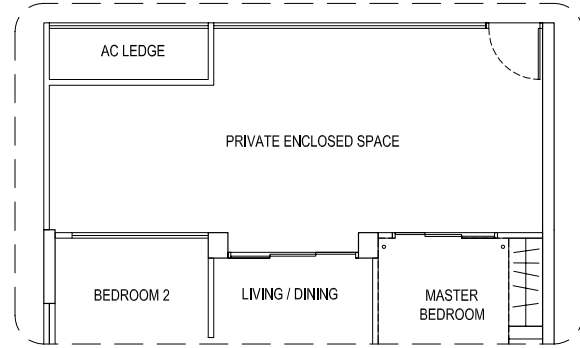

TYPE SB4-P
 89 sq m / 958 sq ft (including PES of 31 sq m / 334 sq ft)
 #01-20, #01-21

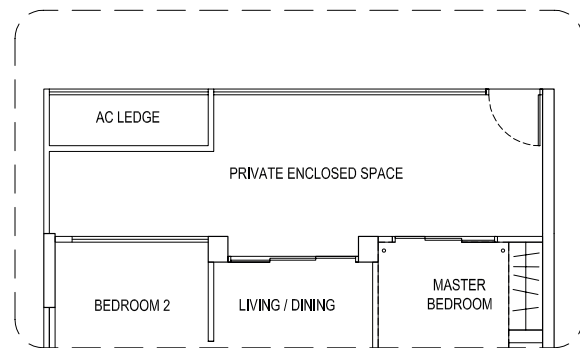

TYPE SB4-P1
 79 sq m / 850 sq ft (including PES of 21 sq m / 226 sq ft)
 #01-27

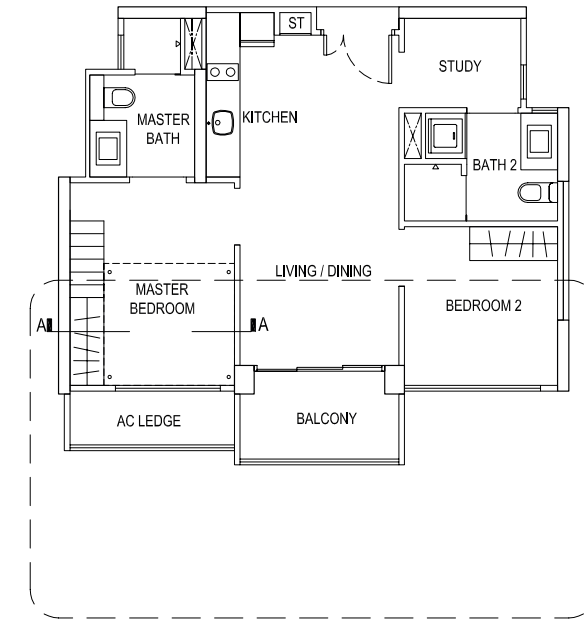

TYPE SB4a
 63 sq m / 678 sq ft
 #02-19 to #20-19

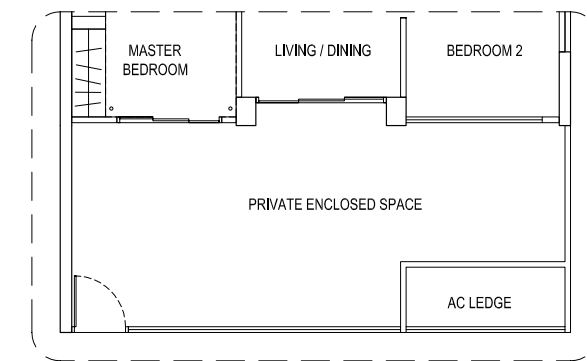

TYPE SB4a-P
 89 sq m / 958 sq ft (including PES of 31 sq m / 334 sq ft)
 #01-19

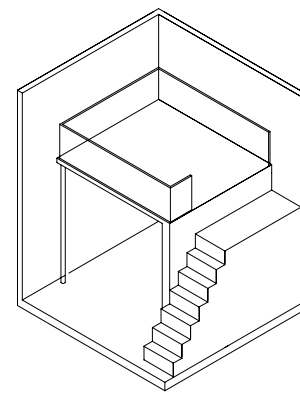

ISOMETRIC VIEW OF PLATFORM
 (MIRROR IMAGE FOR SB4a)

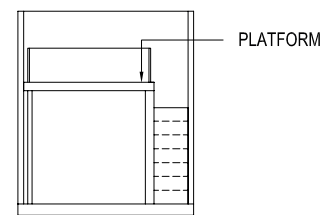

SECTION A-A (MIRROR IMAGE FOR SB4a)
 FLOOR TO FLOOR HEIGHT VARIES.
 3.60M - 2ND, 3RD, 4TH, 6TH, 7TH, 9TH, 10TH, 12TH,
 13TH, 15TH, 16TH, 18TH, 19TH STOREY
 3.85M - 5TH, 8TH, 11TH, 14TH, 17TH STOREY
 4.00M - 1ST AND 20TH STOREY

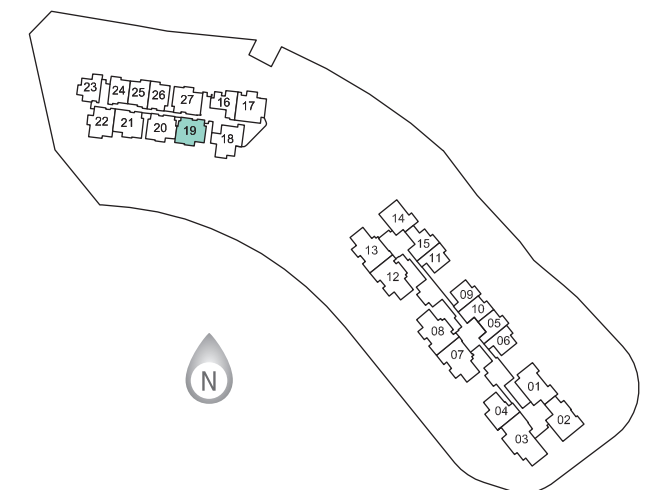

SUITES

CONTEMPORARY, COSY LIVING.

Take advantage of highly functional layouts and efficient space usage. Transform the unique interiors, and make your home at J Gateway your personal expression.



SUITES

1 BEDROOM

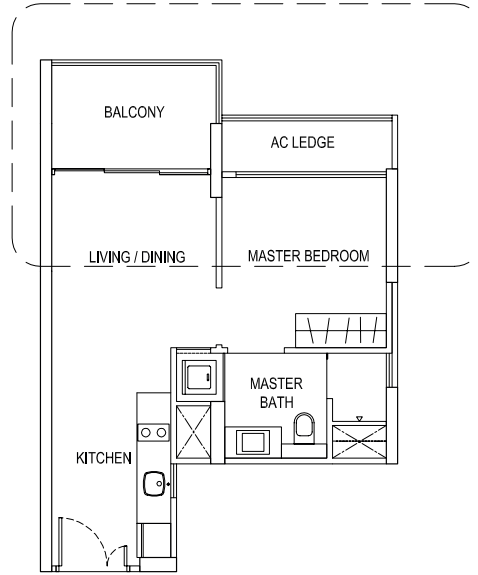

TYPE A

44 sq m / 474 sq ft
 #02-06 to #23-06, #25-06 to #32-06
 #02-09 to #23-09, #25-09 to #32-09
 #02-11 to #23-11, #25-11 to #32-11

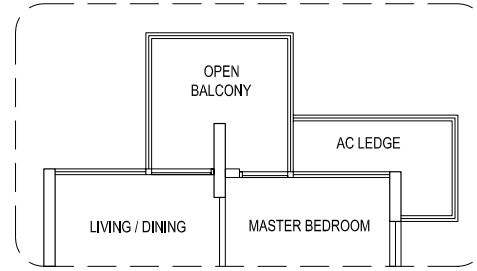

TYPE Aa

45 sq m / 484 sq ft
 #34-06, #34-09

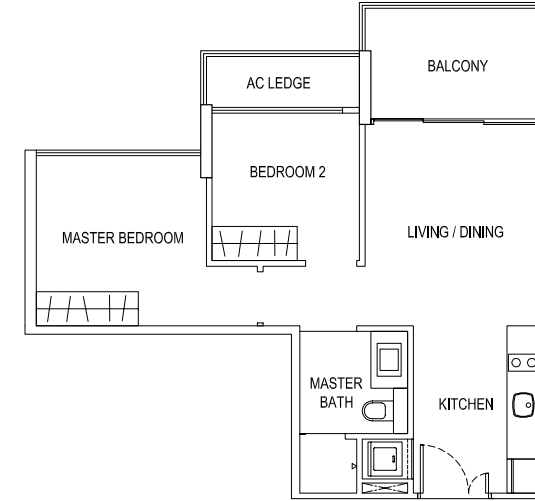

TYPE B

56 sq m / 603 sq ft
 #02-15 to #23-15, #25-15 to #32-15

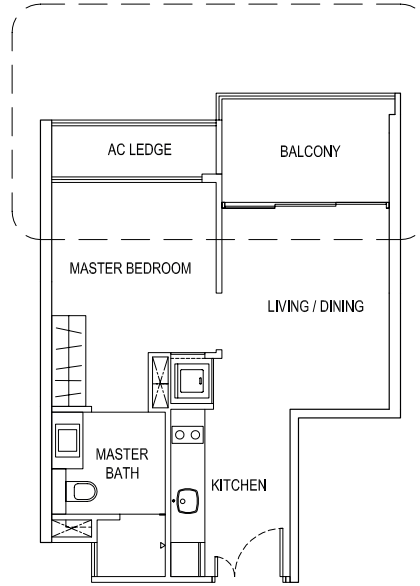

TYPE A1

46 sq m / 495 sq ft
 #02-10 to #23-10, #25-10 to #32-10

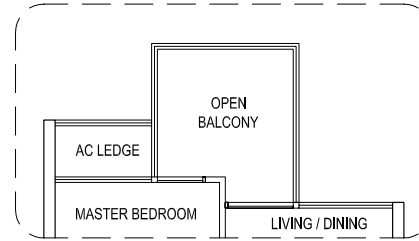

TYPE A1a

45 sq m / 484 sq ft
 #34-10

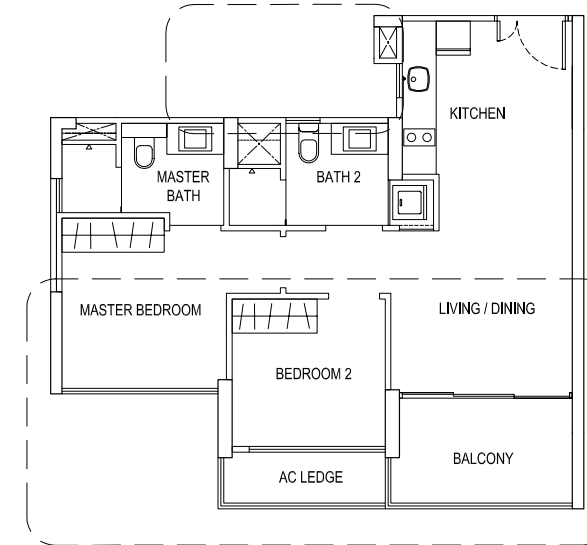

TYPE B1

63 sq m / 678 sq ft
 #02-04 to #23-04, #25-04 to #32-04

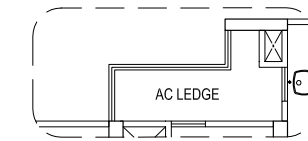

TYPE B1c

64 sq m / 689 sq ft
 #34-04

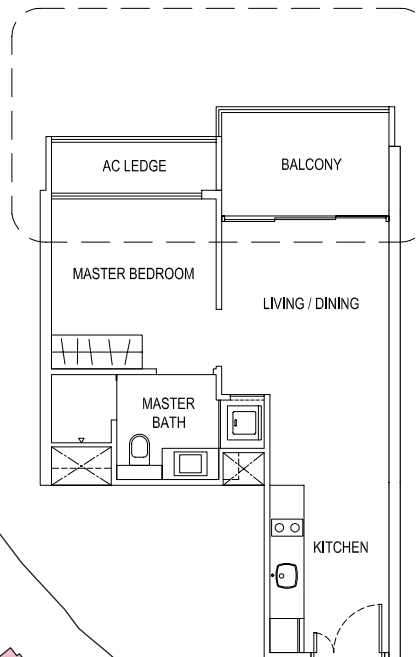

TYPE A2

47 sq m / 506 sq ft
 #02-05 to #23-05, #25-05 to #32-05

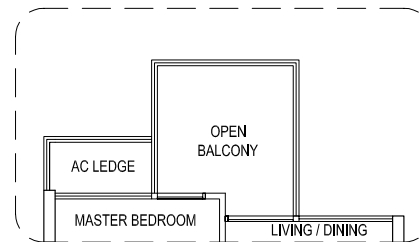

TYPE A2a

46 sq m / 495 sq ft
 #34-05

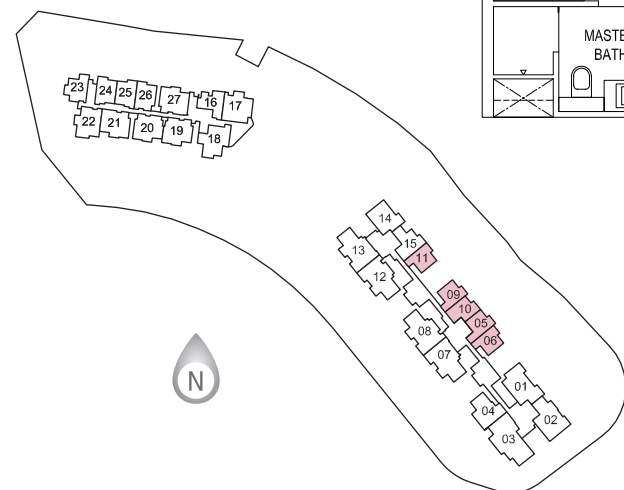
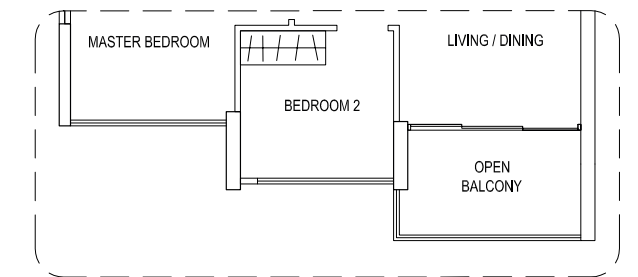

SUITES

2 BEDROOM

SUITES

2 BEDROOM

SUITES

3 BEDROOM

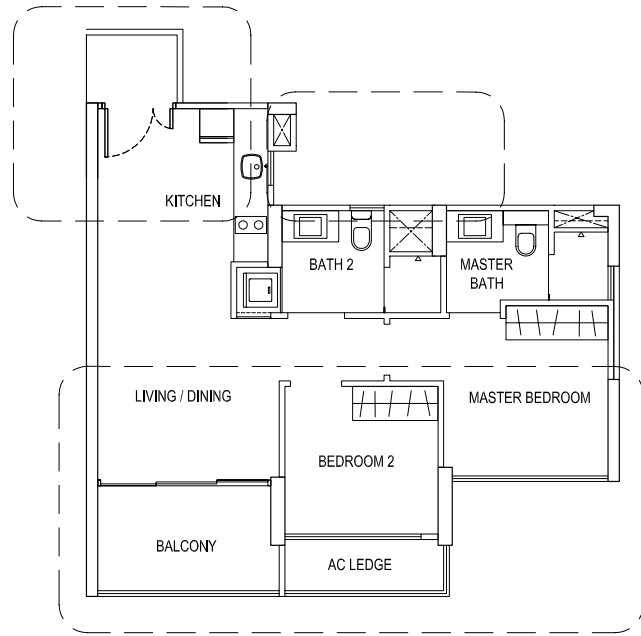

TYPE B1a
65 sq m / 700 sq ft
#25-12 to #32-12

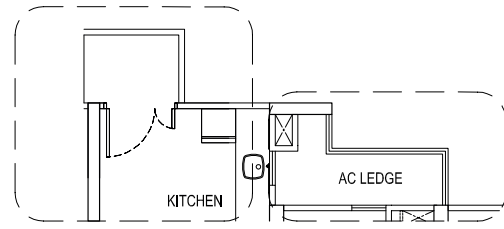

TYPE B1b
66 sq m / 710 sq ft
#34-12

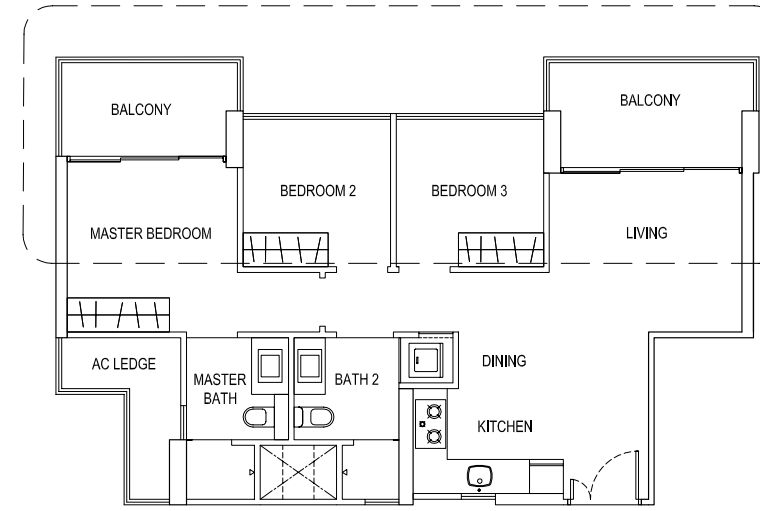

TYPE C
83 sq m / 893 sq ft
#02-01 to #23-01, #25-01 to #32-01,
#34-01 to #36-01

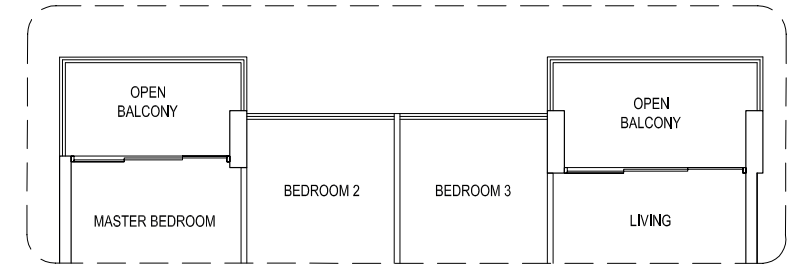

TYPE Ca
83 sq m / 893 sq ft
#37-01



TYPE B2
64 sq m / 689 sq ft
#02-14 to #23-14, #25-14 to #32-14

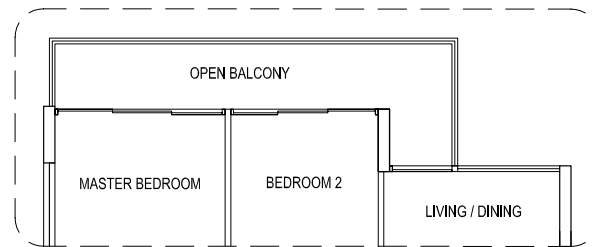

TYPE B2a
67 sq m / 721 sq ft
#34-14

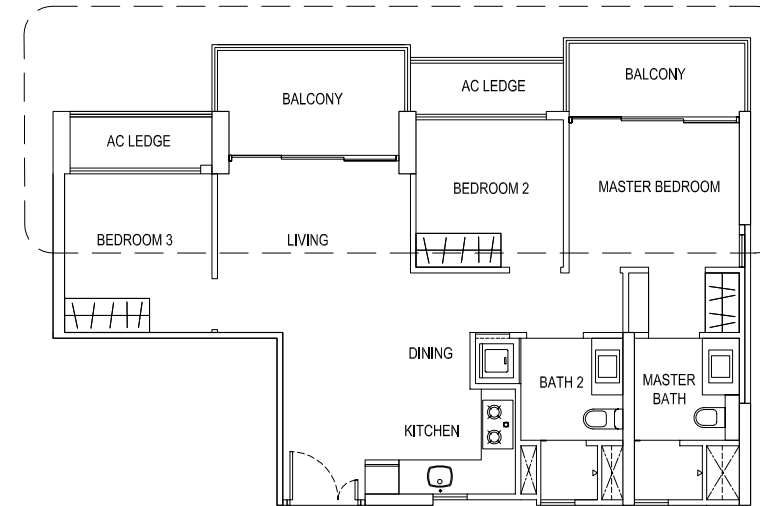

TYPE C1
83 sq m / 893 sq ft
#02-02 to #23-02, #25-02 to #32-02,
#34-02 to #36-02

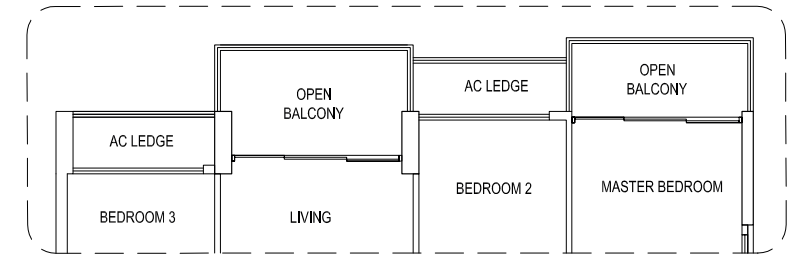

TYPE C1a
83 sq m / 893 sq ft
#37-02

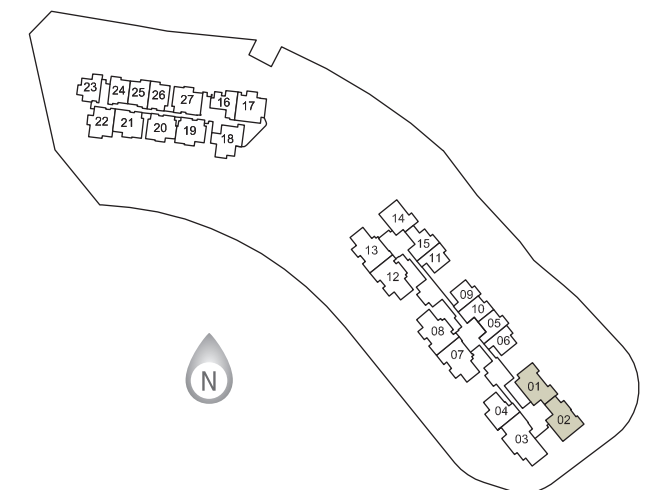
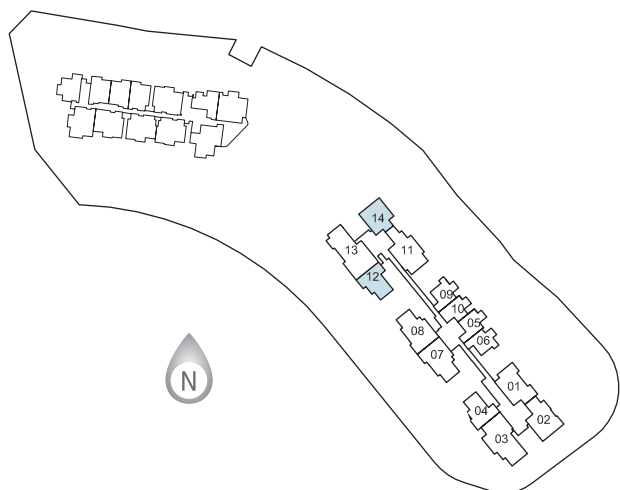

SUITES

3 BEDROOM

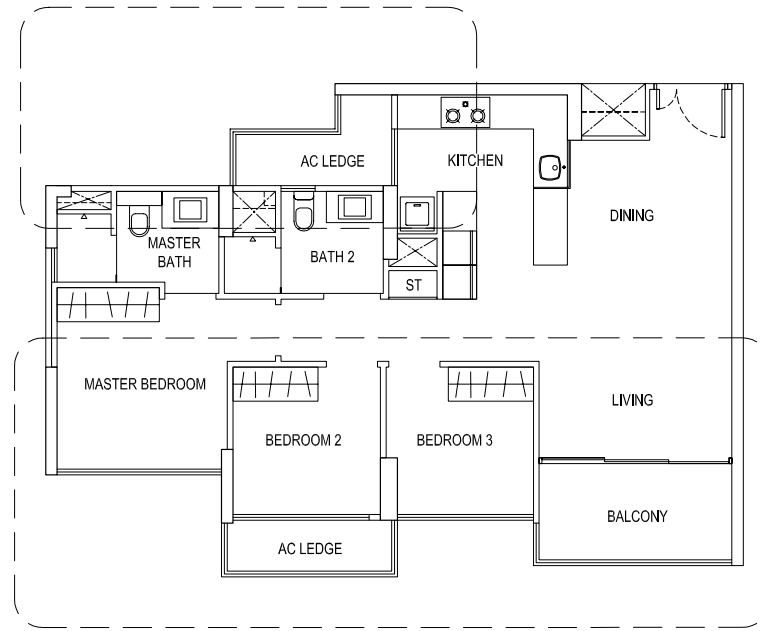

TYPE C2
 88 sq m / 947 sq ft
 #02-08 to #23-08, #25-08 to #32-08,
 #02-12 to #23-12

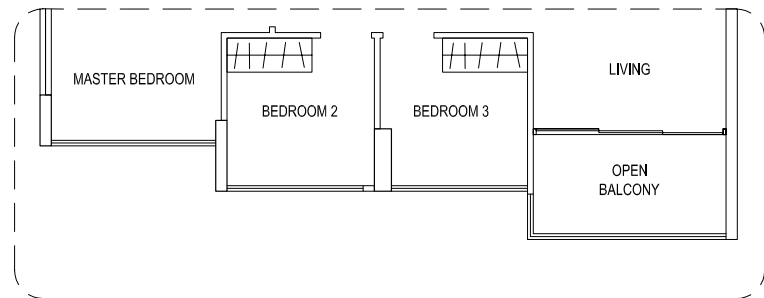
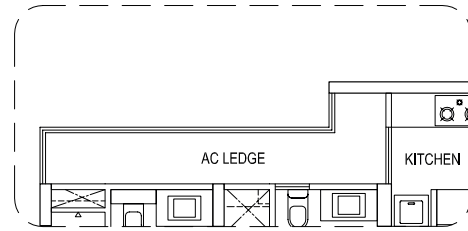

TYPE C2a
 88 sq m / 947 sq ft
 #34-08



SUITES

3 BEDROOM

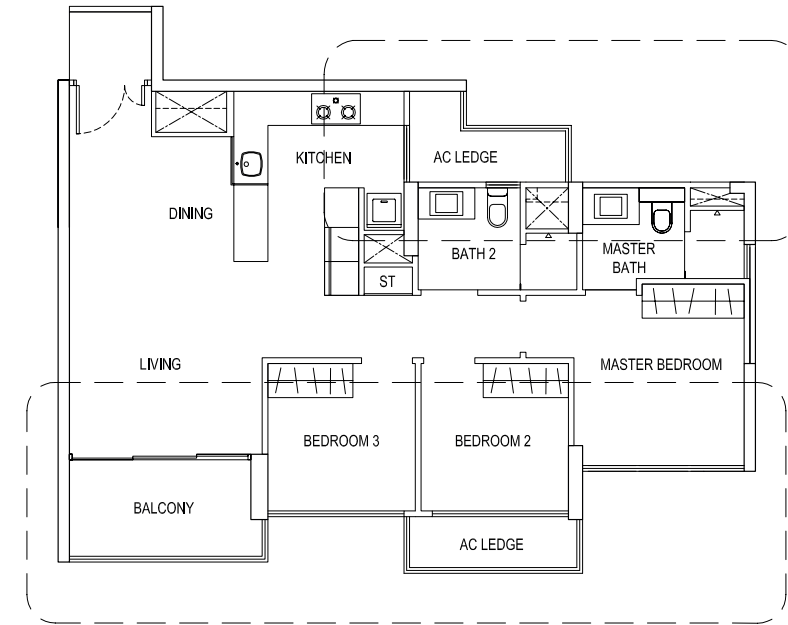

TYPE C2b
 90 sq m / 969 sq ft
 #02-07 to #23-07, #25-07 to #32-07,
 #02-13 to #23-13

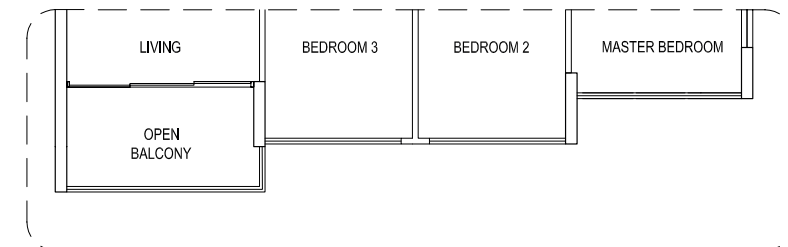
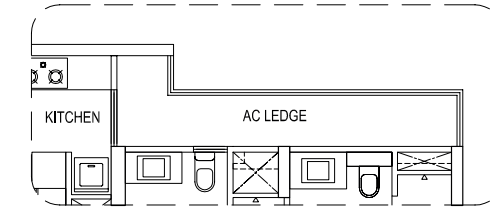

TYPE C2c
 90 sq m / 969 sq ft
 #34-07



SUITES

3 BEDROOM

SUITES

4 BEDROOM

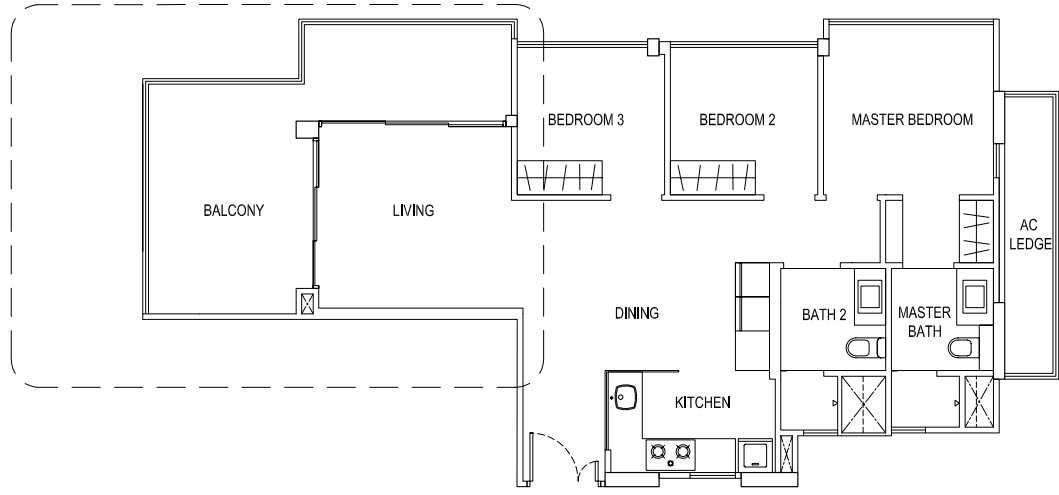

TYPE C3
100 sq m / 1076 sq ft
#35-06

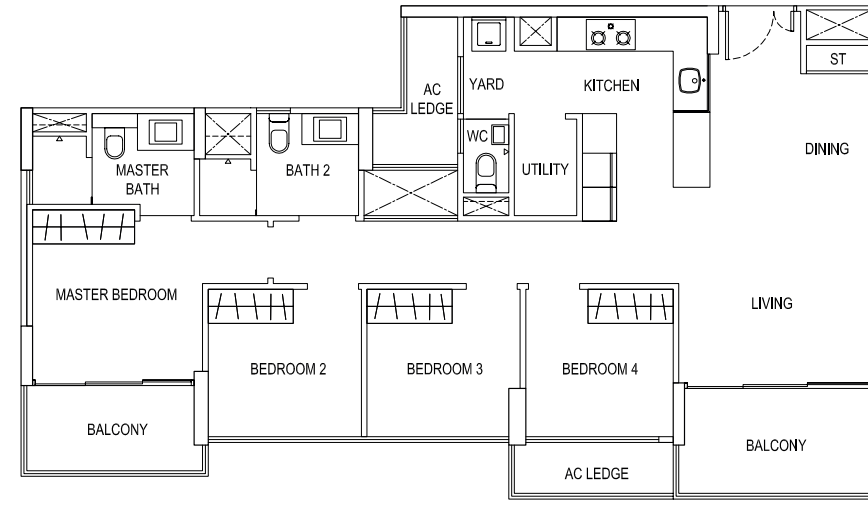

TYPE D
108 sq m / 1163 sq ft
#25-13 to #32-13

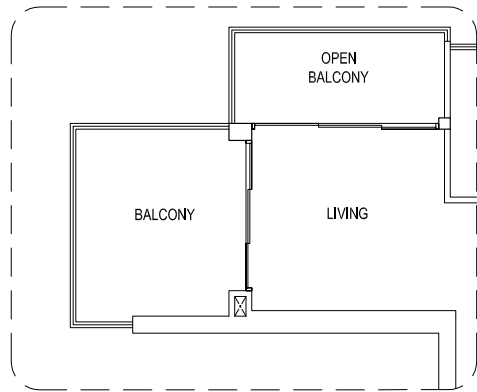

TYPE C3a
98 sq m / 1055 sq ft
#36-06

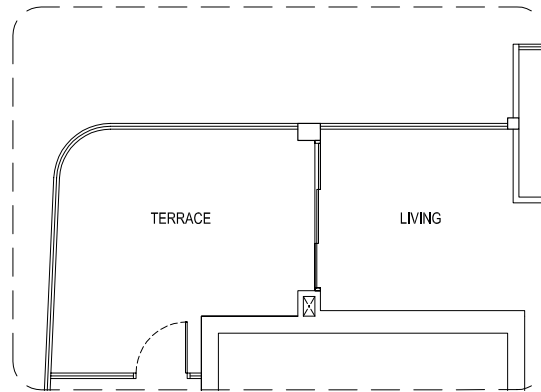

TYPE C3-T
100 sq m / 1076 sq ft (including Terrace of 19 sq m / 205 sq ft)
#37-06

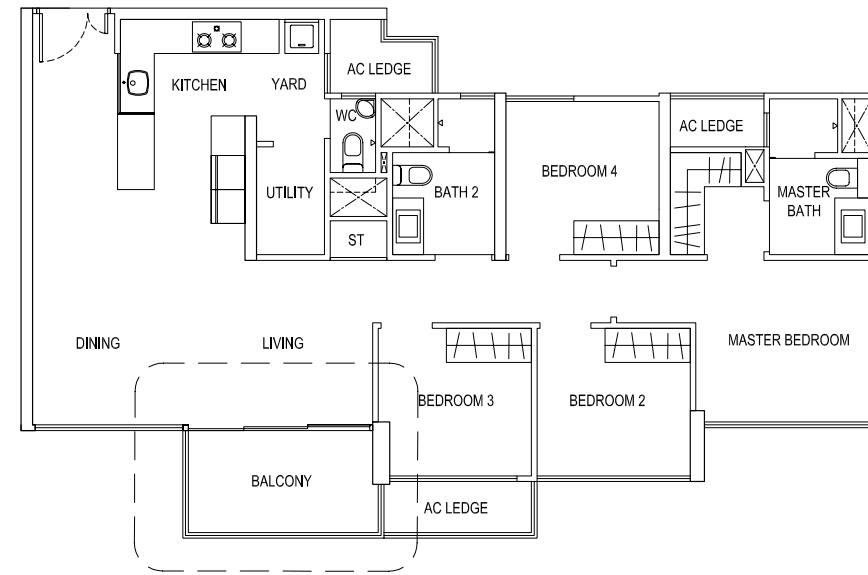

TYPE D1
112 sq m / 1206 sq ft
#02-03 to #23-03, #25-03 to #32-03

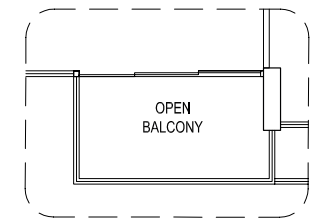

TYPE D1c
112 sq m / 1206 sq ft
#34-03



SUITES

4 BEDROOM

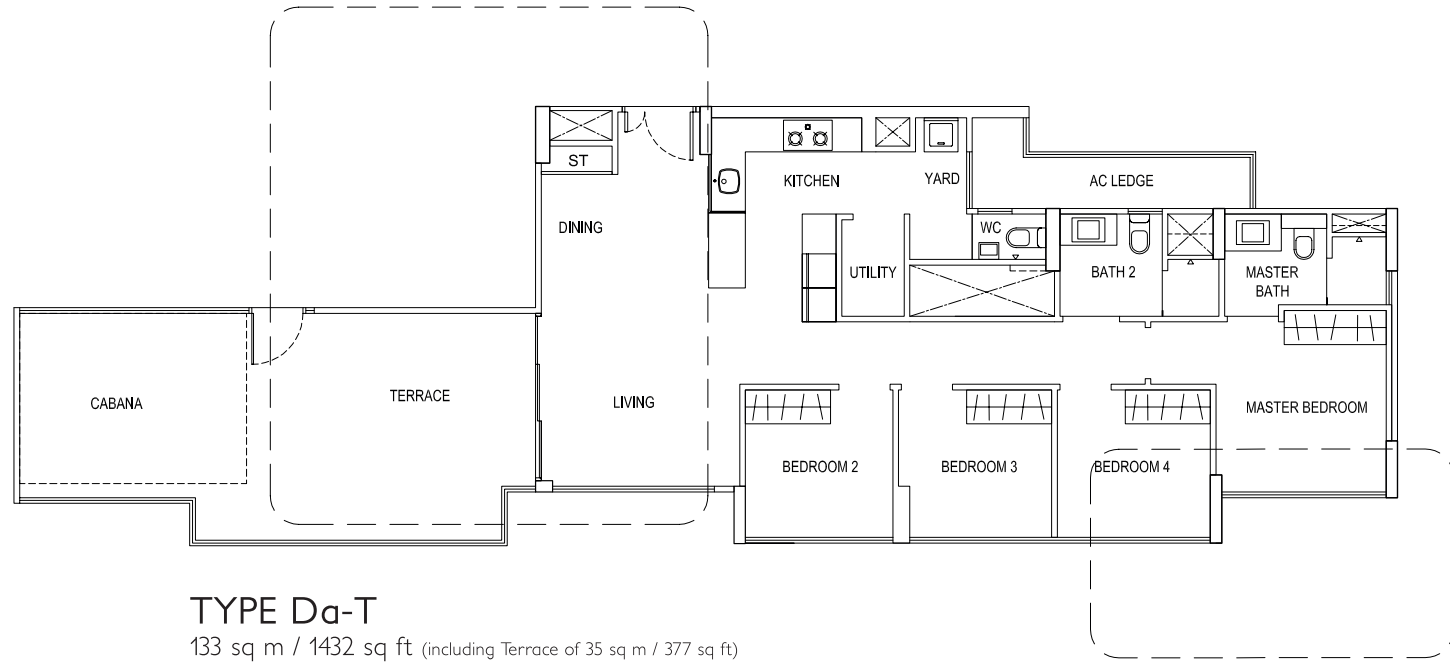

TYPE Da-T

133 sq m / 1432 sq ft (including Terrace of 35 sq m / 377 sq ft)
#35-08

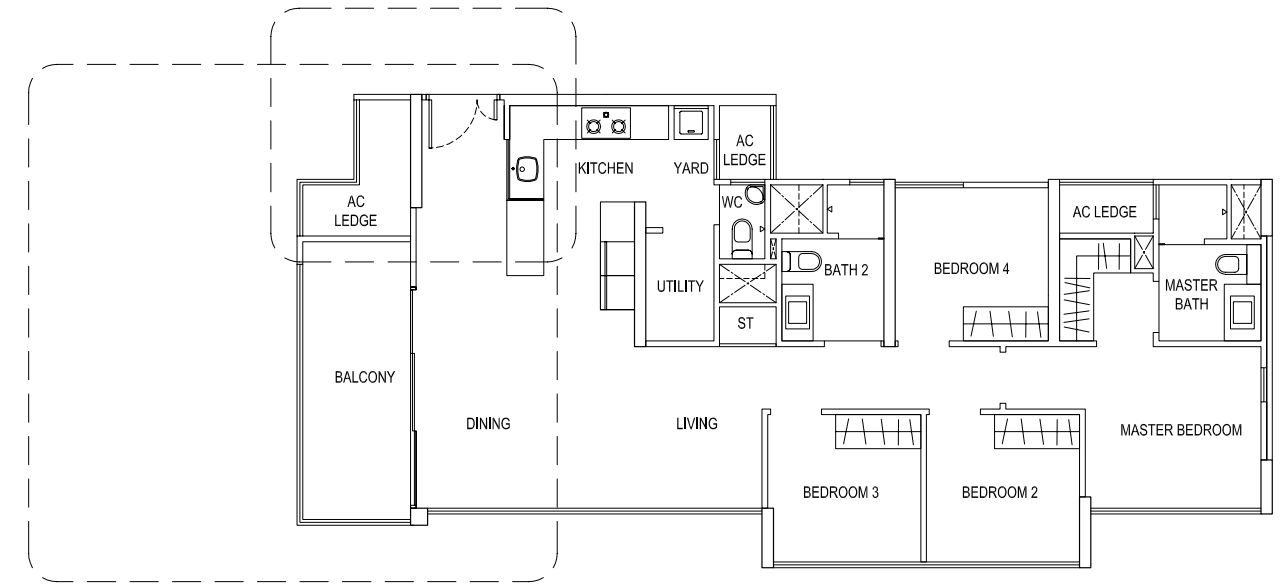

TYPE D1a

115 sq m / 1238 sq ft
#36-03

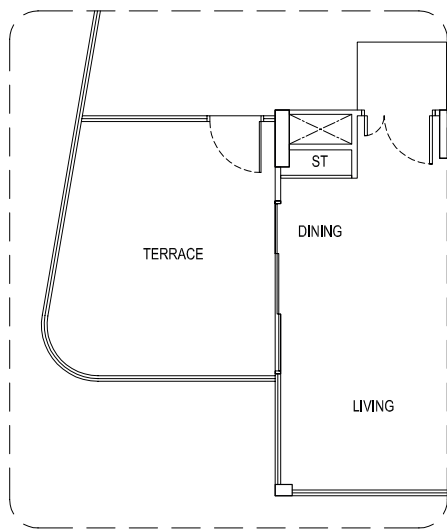
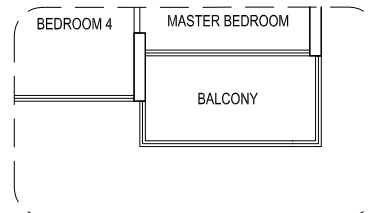
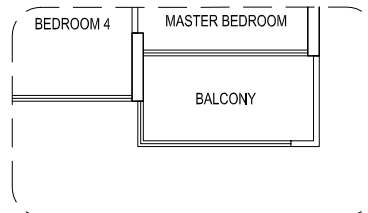

TYPE Da-T1

123 sq m / 1324 sq ft (including Terrace of 18 sq m / 194 sq ft)
#36-08

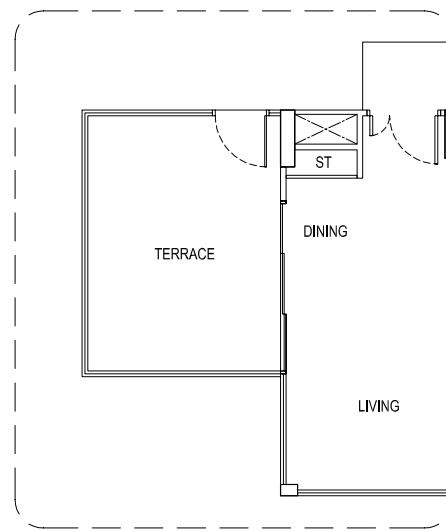

TYPE Da-T2

122 sq m / 1313 sq ft (including Terrace of 17 sq m / 183 sq ft)
#37-08

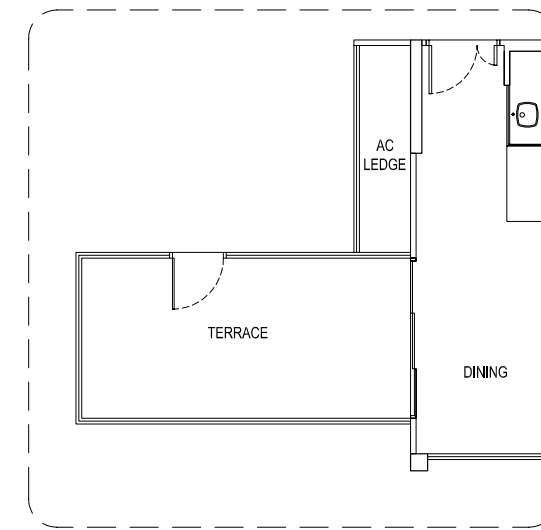

TYPE D1a-T

123 sq m / 1324 sq ft (including Terrace of 18 sq m / 194 sq ft)
#35-03

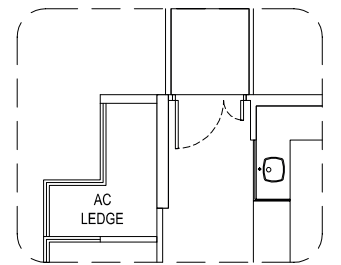

TYPE D1b

117 sq m / 1259 sq ft
#37-03



33rd

STOREY

SKY GARDEN SUITES

TYPE B2-T
70 sq m / 753 sq ft
(including Terrace of 13 sq m / 140 sq ft)
#33-14

TYPE B-T
67 sq m / 721 sq ft
(including Terrace of 18 sq m / 194 sq ft)
#33-15

TYPE A-T
50 sq m / 538 sq ft
(including Terrace of 12 sq m / 129 sq ft)
#33-11

TYPE A-T1
50 sq m / 538 sq ft
(including Terrace of 12 sq m / 129 sq ft)
#33-09

TYPE A1-T
49 sq m / 527 sq ft
(including Terrace of 10 sq m / 108 sq ft)
#33-10

TYPE A2-T
49 sq m / 527 sq ft
(including Terrace of 9 sq m / 97 sq ft)
#33-05

TYPE A-T1
50 sq m / 538 sq ft
(including Terrace of 12 sq m / 129 sq ft)
#33-06

TYPE C-T
97 sq m / 1044 sq ft
(including Terrace of 28 sq m / 301 sq ft)
#33-01

TYPE C1-T
100 sq m / 1076 sq ft
(including Terrace of 29 sq m / 312 sq ft)
#33-02

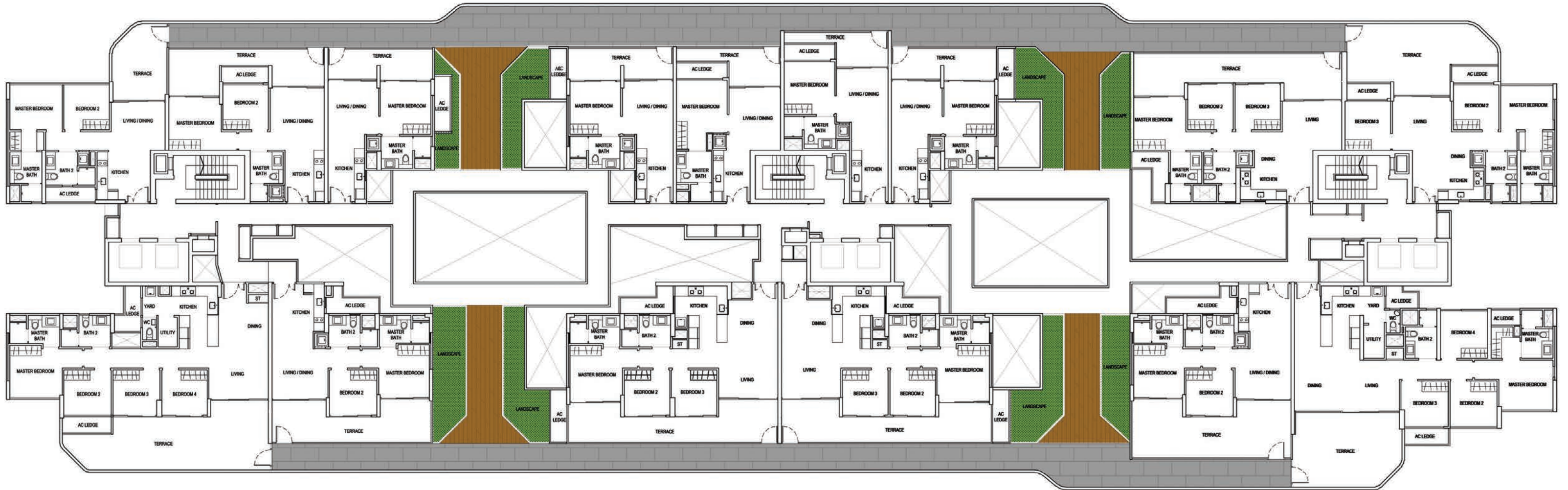

TYPE D-T
132 sq m / 1421 sq ft
(including Terrace of 36 sq m / 388 sq ft)
#33-13

TYPE B1a-T
79 sq m / 850 sq ft
(including Terrace of 20 sq m / 215 sq ft)
#33-12

TYPE C2-T
106 sq m / 1141 sq ft
(including Terrace of 25 sq m / 269 sq ft)
#33-08

TYPE C2b-T
108 sq m / 1163 sq ft
(including Terrace of 25 sq m / 269 sq ft)
#33-07

TYPE B1-T
87 sq m / 936 sq ft
(including Terrace of 29 sq m / 312 sq ft)
#33-04

TYPE D1-T
131 sq m / 1410 sq ft
(including Terrace of 27 sq m / 291 sq ft)
#33-03



DAILY MOMENTS MADE TRULY DELIGHTFUL.



Embrace the stage with zest and panache – your home at J Gateway is your stage of elegance and sophistication. Graced with premium kitchen appliances, integrated fridge, washer cum dryer, digital lockset, designer bathroom fittings and bidet, it complements your lifestyle perfectly and fills every day with enjoyment.



Amidst the panoply of luxurious offerings, care for the environment is at the heart of J Gateway. They include a pneumatic refuse disposal system, Low-E (Low-Emissivity) windows and solar panels, garnering it the coveted Green Mark Gold Plus award.



SPECIFICATIONS

1. FOUNDATION

Reinforced concrete piles and/or piled raft and/or raft.

2. SUPERSTRUCTURE

Reinforced concrete structure.

3. WALLS

(a) External

- Reinforced concrete and/or common clay bricks and/or texture coating to selected walls

(b) Internal

- Reinforced concrete and/or common clay bricks and/or lightweight concrete blocks and/or dry wall partition

4. ROOF

Reinforced concrete structure with appropriate insulation and/or waterproofing system.

5. CEILING

(i) Unit

- Living/Dining, all Bedrooms, Study, Hallway
- Skim coat plaster with emulsion paint and/or part fibrous plasterboard with emulsion paint

Kitchen, all Bathrooms, Utility, Yard, WC, Private Enclosed Space, Balcony, Terrace

- Skim coat plaster with emulsion paint and/or part moisture resistant ceiling board with emulsion paint

Store

- Skim coat plaster with emulsion paint

(ii) Common Areas

Management Office, Mail-Box Area, Gymnasium, Function Room, Meeting Room

- Skim coat plaster with emulsion paint and/or part fibrous plasterboard with emulsion paint

Lift Lobbies, Changing Rooms and Toilets

- Skim coat plaster with emulsion paint and/or part moisture resistant ceiling board with emulsion paint

Basement Carparks, Enclosed Common Staircases, Corridors and Guard House

- Skim coat plaster with emulsion paint

6. FINISHES

(a) Wall

(i) Unit

- Living/Dining, all Bedrooms, Study, Store, Utility, Hallway
- Cement/sand plaster with emulsion paint and/or skim coat with emulsion paint

Master Bath

- Composite marble and/or homogenous tiles

Bath 2, WC

- Homogenous tiles and/or ceramic tiles

Kitchen, Yard, Private Enclosed Space, Balcony, Terrace and Roof Terrace

- Homogenous tiles and/or ceramic tiles and/or cement/sand plaster with emulsion paint

(ii) Common Areas

Main Drop-Off/Waiting Area, Communal Areas, Changing Rooms and Toilets

- Stone and/or homogenous tiles and/or ceramic tiles and/or cement/sand plaster with emulsion paint

Lift Lobbies, Corridors, Management Office, Guard House, Gymnasium, Function Room, Meeting Room, Mail Area, Enclosed Staircases, Carpark and Other Areas

- Cement/sand plaster with emulsion paint and/or skim coat cement/sand plaster with emulsion paint

Note:*No tiles behind and below kitchen cabinets, bathroom cabinets and mirror.

*Wall surface above the false ceiling level will be left in its original bare condition.

(b) Floor

(i) Unit

Living/Dining, Kitchen of all Type C, D and PH units

- Compressed marble

Living/Dining, Kitchen of all Type SA, SB, A and B units, Yard, Store, Utility, Hallway, Private Enclosed Space, Balcony, Terrace and Roof Terrace

- Homogenous tiles and/or ceramic tiles with skirting

Master Bedroom of all Type SA units and Study

- Homogenous tiles and/or ceramic tiles with timber skirting

All Bedrooms except Master Bedroom of all Type SA units

- Timber-strips with skirting

Master Bath

- Composite marble and/or homogenous tiles

Bath 2 and WC

- Homogenous tiles and/or ceramic tiles

(ii) Common Areas

Main Drop-Off Area, Lift Lobbies, Corridors, Changing Rooms and Toilets, Guard House, Mail-Box Areas, Management Office, Function Room and Meeting Room

- Stone and/or porcelain and/or homogenous tiles

Gymnasium

- Rubber-mat flooring and/or homogenous tiles and/or carpet

Enclosed Staircases

- Cement/sand screed with non-slip nosing tiles

Basement Carparks and Driveways

- Cement/sand screed with hardener

Landscape Deck and Pool Deck

- Composite timber and/or stone and/or homogenous tiles

7. WINDOWS

Powder coated aluminum framed windows with tinted and laminated tempered glass and Low-E glass to designated areas, as may be required by authorities.

8. DOORS

(i) Approved fire-rated timber doors to Main Unit entrance

(ii) Hollow-core timber doors to all Bedrooms, Store and Bathrooms

(iii) Powder coated aluminium framed glass swing and/or sliding doors to Private Enclosed Space, Balcony, Terrace and Roof Terrace

(iv) Aluminium bi-fold door to WC and Utility

(v) Metal blast doors for all Storey Staircase Household Shelters

(vi) Selected quality locksets and ironmongery to all doors

9. SANITARY FITTINGS

(a) Master Bath

- 1 shower mixer with hand shower
- 1 basin with solid surface vanity top
- 1 wall hung water closet
- 1 towel rail and/or robe hooks
- 1 toilet-paper holder
- 1 mirror

(b) Bath 2

- 1 shower mixer with hand shower
- 1 basin with solid surface vanity top
- 1 pedestal water closet
- 1 towel rail and/or robe hooks
- 1 toilet-paper holder
- 1 mirror

(c) WC

- 1 shower set
- 1 pedestal water closet
- 1 basin with tap
- 1 toilet-paper holder
- 1 bib tap

(d) Private Enclosed Space, Terrace and Roof Terrace

- 1 bib tap

10. ELECTRICAL INSTALLATION

All electrical wirings are concealed except for electrical wirings in conduits exposed above false ceiling and exposed trunkings within distribution board compartments or cupboards.

11. TV/TELEPHONE

TV/Telephone points shall be provided in accordance with the Electrical Schedule.

12. LIGHTNING PROTECTION

Lightning protection system shall be provided in accordance with current edition of Singapore Standard SS555.

13. PAINTING

(a) External Walls

- External paint with spray texture coating to designated area

(b) Internal Walls

- Emulsion paint

14. WATERPROOFING

Waterproofing shall be provided for the floor of Bathrooms, WC, Kitchen, Yard, Private Enclosed Space, Balcony, Terrace and Roof Terrace, Pool, Changing Rooms, and Toilets, Pool Deck, Water Feature, RC Flat Roof and Basement where applicable.

15. DRIVEWAY AND CAR PARK

(a) Granite pavers to Main Entrance Driveway

(c) Cement/sand screed floor with hardener to applicable areas of Carparks and driveways at Basements

16. RECREATION FACILITIES

(i) Swimming Pool

(ii) Lap Pool

(iii) Children's Pool

(iv) Jacuzzi

(v) Function Room

(vi) Meeting Room

(vii) Tennis Court

(viii) Indoor and Outdoor Gymnasium

(ix) BBQ Area

(x) Dining Pavilion

(xi) Children's Playground

17. ADDITIONAL ITEMS

(a) Kitchen

- (i) Solid surface countertop
- (ii) High and low level kitchen cabinets, sink with mixer, cooker hood, hob and built-in oven
- (iii) Induction hob for all Type SA, SB, A and B units

(b) Bedrooms

Built-in wardrobes (except Study)

(c) Air-conditioning

Wall-mounted fan coil unit air-conditioning system to Living, Dining, Bedrooms and Study

(d) Water Heaters

Hot water supply from electrical heaters to all Bathrooms and Kitchen

(e) Security

- (i) Audio video intercom system
- (ii) Proximity card access
- (iii) Carpark barrier system at guardhouse
- (iv) CCTV surveillance for general security

(f) Gas

Town gas supply to cooker hob at Kitchens except all Type SA, SB, A and B units

(g) Digital Lockset

For all Main Unit door

(h) Open Terraces and Balconies

Mild steel railing and/or aluminium railing and/or parapet wall

(i) Private Enclosed Space Gates

Mild steel or aluminium gate

DISCLAIMER:

While every reasonable care has been taken in preparing this brochure and in constructing the models and showflats, neither the Developer nor its agents will be held responsible for any inaccuracies or omissions. Visual representations, models, showflat displays and illustrations, photographs, art renderings and other graphic representations and references are intended to portray only artistic impressions of the development and décor and cannot be regarded as representations of fact. All areas and other measurements are approximate measurements and are subject to final survey. The property is subject to final inspection by the relevant authorities to comply with the current codes of practice.

All information, specifications, renderings, visual representations and plans are current at the time of publication and are subject to change as may be required by us and/or the relevant authorities. All statements are believed to be correct but shall not be regarded as statements or representations of fact. All plans and models are not to scale unless expressly stated and are subject to any amendments which are required or approved by the relevant authorities. The Sale and Purchase Agreement shall form the entire agreement between the Developer and the Purchaser and shall supersede all statements, representations or promises made prior to the signing of the Sale and Purchase Agreement and shall in no way be modified by any statements, representations or promises made by us or our agents, which are not embodied in the Sale and Purchase Agreement.

Developer: MCL Land (Gateway) Pte Ltd (ROC: 201213952N) • Developer Licence: C1048 • Location: Lot(s) 08773X MK05 at Boon Lay Way / Gateway Drive • Land Tenure: 99 years commencing from 28 August 2012 • Building Plan No.: A1698-00323-2012-BP01 dated 12 April 2013 • Expected Date of Vacant Possession: 31 May 2017 • Expected Date of Legal Completion: 31 May 2020

CORPORATE PROFILE

MCL Land is a leading property group with a long track record of building quality homes in Singapore and Malaysia over the past 40 years. Their commitment to being a premier and reputable property developer inspires them to be equally dedicated to absolute customer satisfaction. MCL Land holds an impressive portfolio of prime residential developments, including Terrasse, UBER 388, Este Villa, The Estuary, Parvis, Hillcrest Villa, Ripple Bay, Hallmark Residences and Palms @ Sixth Avenue. J Gateway, their latest project, will be no different, and promises to deliver the same superb level of quality and excellence that are their hallmarks.



ESTE VILLA



PALMS @ SIXTH AVENUE



UBER 388



TERRASSE



HALLMARK RESIDENCES



RIPPLE BAY

MCL Land
A member of the Hongkong Land Group

78 Shenton Way #33-00 S(079120)
Tel no: (65) 6221-8111
www.mclland.com.sg
www.jgateway.com.sg