



Tropika
EAST

“troika - a group of three”

Inspired from the words Troika and Tropical, Tropika East offers you 3 wonderful reasons to call this home:

- * *Private Residential Enclave, epitomising sophistication*
- * *Peace & Tranquility, within your Tropical Haven*
- * *Paya Lebar Central, the new hive of activity*





*Private Residential Enclave
epitomizing Sophistication*

A 5-storey development comprising 105 freehold condominium units within a private landed housing enclave, Tropika boasts contemporary architectural design, lush greenery and resplendent waterscapes.

Tropika offers 26 varying layouts from exclusive 1 bedroom to luxurious 3 bedrooms and spacious penthouses, including special high-ceiling loft units and units with private pools; an array of choice options for every discerning owner.



Peace & Tranquility within your Tropical Haven

Relish serene tranquillity and exclusivity at **Tropika**. In a harmonious environment of pure calm, behold unobstructed views of beautiful landscaping as you take a relaxing stroll alongside *Lily Ponds*. Traipse over to *The Club House* and enjoy a dip in the 25m luminous *Lap Pool* and outdoor *Hydro Therapy Pool* amidst the blissful surroundings.



JLN RIMAU
Tropika EAST
 FOO KIM LIN RD



Paya Lebar Central – the new hive of activity

A short drive away is Paya Lebar Central, the upcoming 12-hectare commercial hub of the East, with more than 5 million square feet of retail, food, hotel and office developments. The new upcoming malls are Paya Lebar Square and OneKM. Simply one stop from the Paya Lebar Interchange MRT station, **Tropika** has easy access to the new hive of activity.

Soak in the heritage and local character at the redeveloped Geylang Serai Market and delight in waterfront activities, dining and shopping along the newly constructed Geylang River stretch.

Lifestyle activities are abound with Parkway Parade and 112 Katong within easy reach. Reputable schools like Maha Bodhi and Tao Nan School are also located within the vicinity. In addition, home dwellers of **Tropika** will also enjoy easy access to Eunos MRT and the upcoming Kaki Bukit MRT stations.

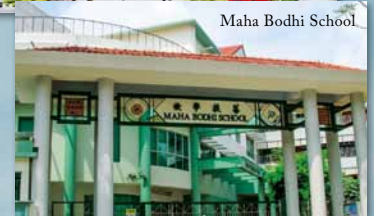

Artist Impression of Paya Lebar Square

Step into harmony

with nature at the Bedok Reservoir and East Coast Park within the vicinity and well connected via the Siglap Park Connector.



East Coast Park



Siglap Park Connector



Bedok Reservoir Park

Congregate with loved ones

and friends over dinner at the multitude of modern eateries along East Coast Road, Katong and Siglap Village, as well as the upcoming integrated malls and shopping hubs at Paya Lebar Central.





Tropika East,

your private home steeped in heritage and character within a historical housing estate. Set within an expansive land area of more than 52,000 square feet with wide frontages of more than 120m on both roads, the building blocks are arranged in a linear manner, hence units do not overlook each other, ensuring unmatched privacy.

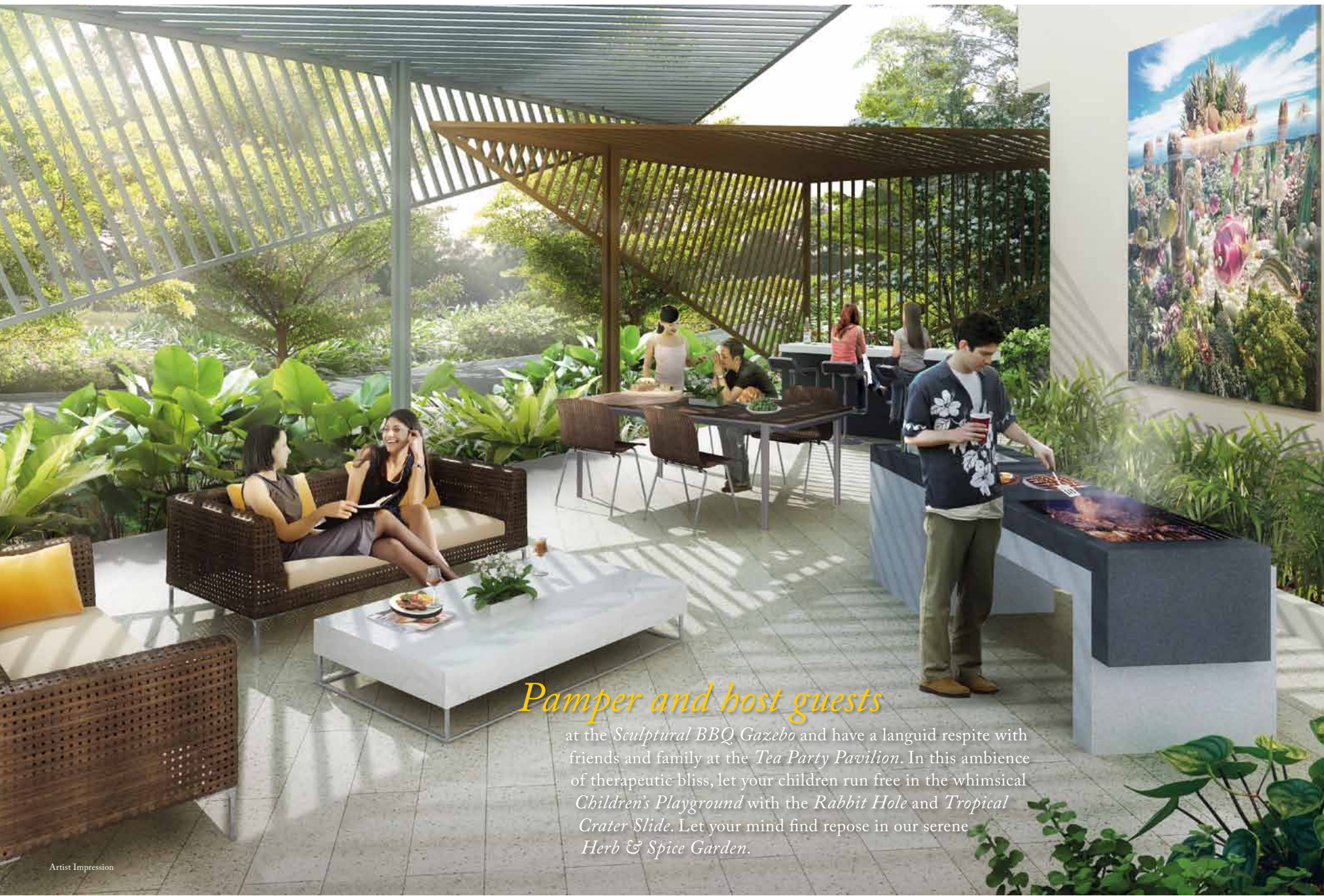

Pamper and host guests

at the *Sculptural BBQ Gazebo* and have a languid respite with friends and family at the *Tea Party Pavilion*. In this ambience of therapeutic bliss, let your children run free in the whimsical *Children's Playground* with the *Rabbit Hole* and *Tropical Crater Slide*. Let your mind find repose in our serene *Herb & Spice Garden*.



Revitalise your body,

mind and soul in the *Rejuvenation Courtyard* amidst the verdant hanging greens and soothing sounds of flowing water. Soak in the warm sun during the day and give your thoughts repose under the wide, starry sky during the nights. Relish the warm currents and healing touches of the therapeutic outdoor *Hydro Therapy Pool* to reward a hard day's work.

SITE PLAN



LEGEND

- | | | |
|----------------------------|---------------------------|---------------------------|
| A – Guard House | H – Rabbit Hole | O – Sculptural BBQ Gazebo |
| B – Lap Pool | I – Children’s Playground | P – The Club House |
| C – Wading Pool | J – Tropical Crater Slide | Q – Tea Party Pavilion |
| D – Sun Deck | K – Fitness Corner | R – Private Pool |
| E – Hydro Therapy Pool | L – Lily Pond | S – Drop Off Point |
| F – Aqua Spa Seat | M – Brook Walk | T – Gymnasium |
| G – Rejuvenation Courtyard | N – Herb and Spice Garden | U – Side Gate |

UNIT DISTRIBUTION CHART



1 FOO KIM LIN ROAD

UNIT LEVEL	1	2	3	4	5	6	7	8	9	10	11	12	13
5	PH1	PH6	PH7	PH2	PH3	PH10	PH11	PH8	PH8	PH11	PH10	PH3	PH4
4	A1	B1	B2	A2	A3	BS	C1	B3	B3	C1	BS	A3	A4
3	A1	B1	B2	A2	A3	BS	C1	B3	B3	C1	BS	A3	A4
2	A1	B1(PP)	B2	A2	A3	BS	C4	B3	B3	C1(PP)	BS	A3	A4
1	A1(P)	B1(P)		A2(P)	A3(P)	BS(P)	C1(P)	B3(P)				A3(P)	A4(P)

3 FOO KIM LIN ROAD

UNIT LEVEL	14	15	16	17	18	19	20	21	22
5	PH5	PH5	PH12	PH3	PH9	PH4	PH9	PH3	PH12
4	A5	A5	C2	A5	B4	A4	B4	A3	C2
3	A5	A5	C2	A5	B4	A4	B4	A3	C2
2	A5	A5	C3	A5	B4	A4	B4	A3	C2
1	A5(P)		C2(P)	A5(P)	B4(P1)	A4(P)	B4(P)	A3(P1)	C2(P1)

LEGEND

A	1 Bedroom	B	2 Bedroom	BS	2 Bedroom + Study	C	3 Bedroom	PH	Penthouse
---	-----------	---	-----------	----	-------------------	---	-----------	----	-----------

1 BEDROOM - LOFT

TYPE A3(P)

#01 - 12

Mirror Image

#01 - 05, #01 - 17

41 sq m / 441 sq ft

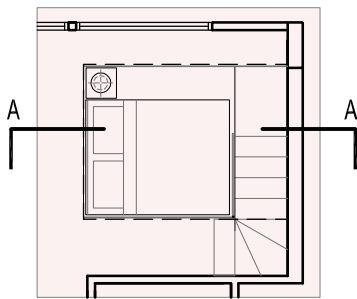

Loft Platform

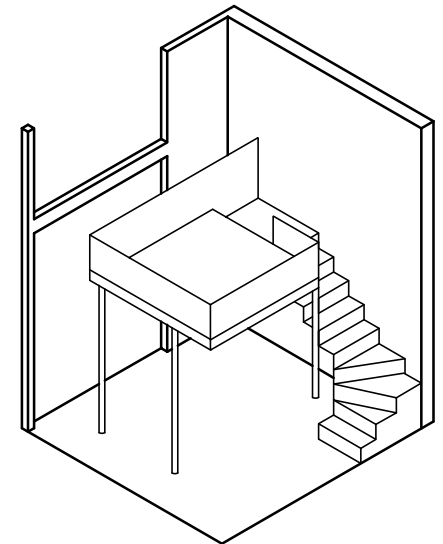
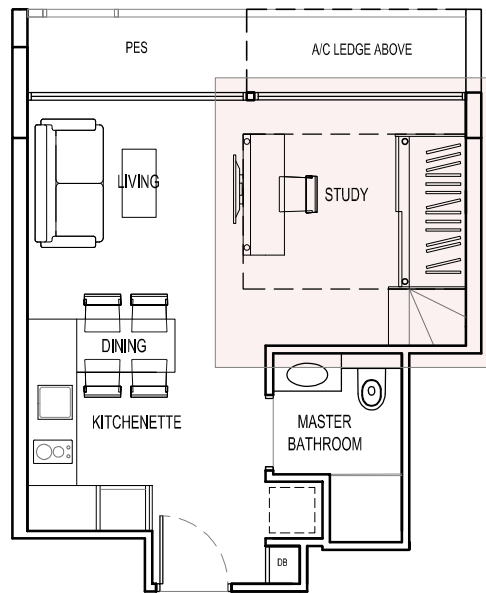

Isometric of Loft Platform

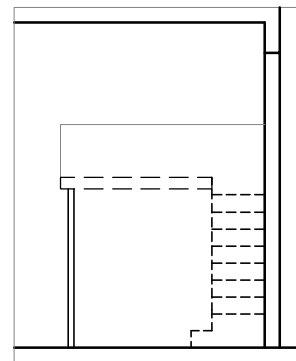

Section A-A
Floor to Floor Height - 4.5m

*The plans are subject to change as may be required or approved by the relevant authorities.
These are not drawn to scale and are for the purpose of visual presentation of the different
layouts that are available. Area estimates only and are subject to final survey.*

SCALE

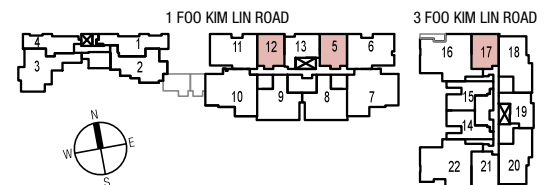

1 BEDROOM - LOFT

TYPE A3(P1)

#01 - 21

44 sq m / 474 sq ft

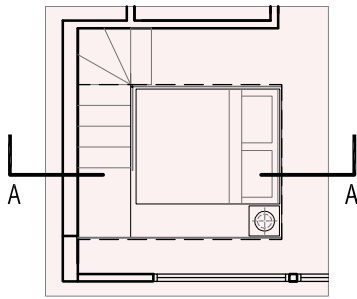

Loft Platform

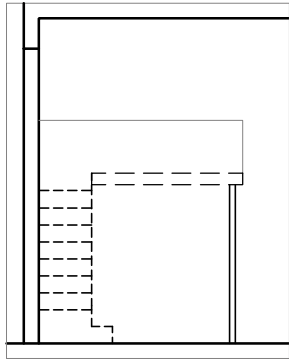

Section A-A
Floor to Floor Height - 4.5m

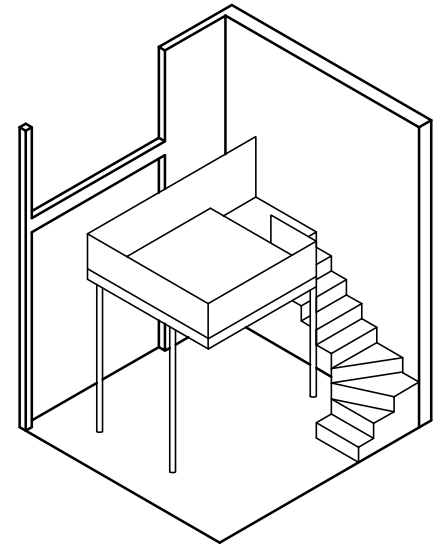
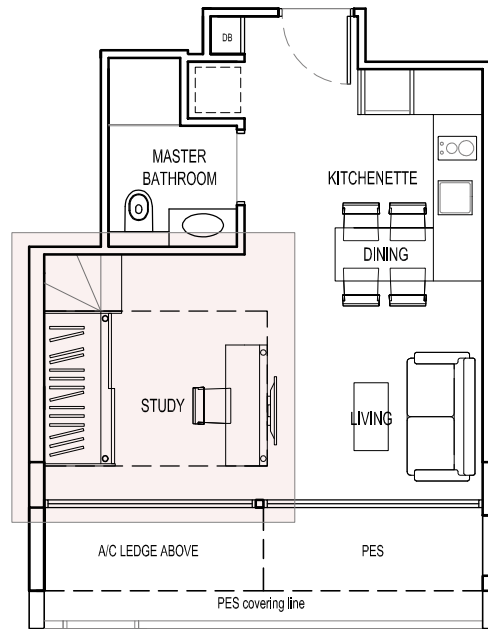

Isometric of Loft Platform

The plans are subject to change as may be required or approved by the relevant authorities. These are not drawn to scale and are for the purpose of visual presentation of the different layouts that are available. Area are estimates only and are subject to final survey.

SCALE

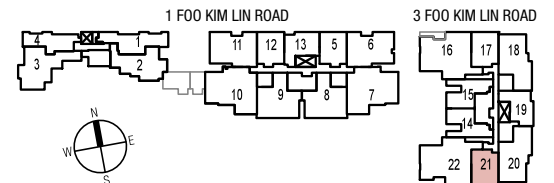

1 BEDROOM

TYPE A1

#02 – 01, #03 – 01, #04 – 01

49 sq m / 527 sq ft

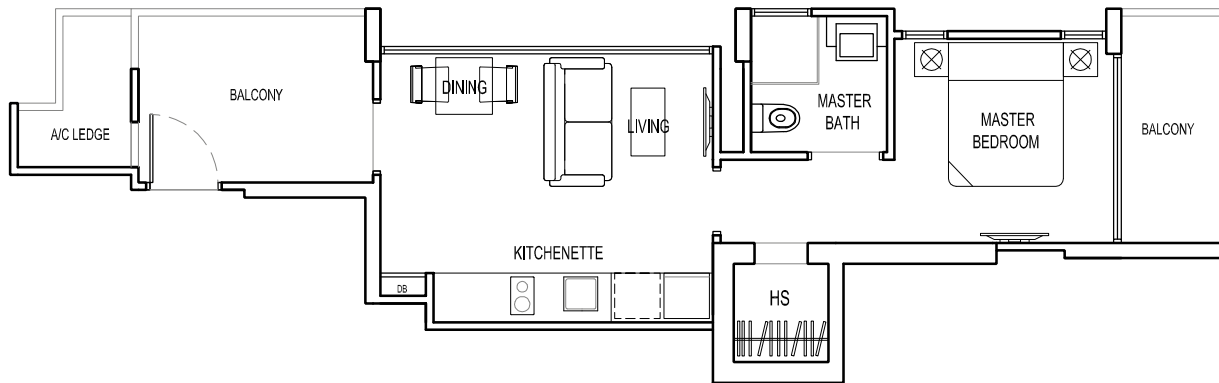

TYPE A1(P)

#01 – 01

49 sq m / 527 sq ft

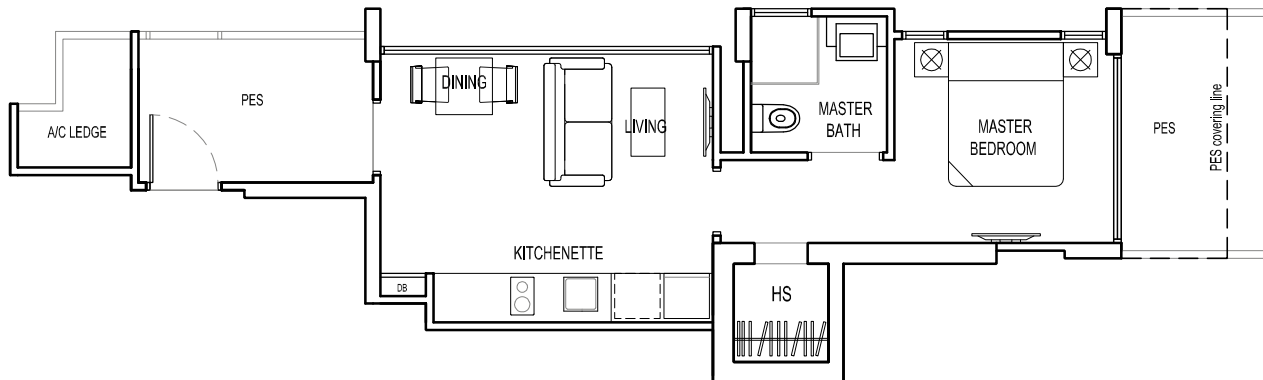

The plans are subject to change as may be required or approved by the relevant authorities.
These are not drawn to scale and are for the purpose of visual presentation of the different
layouts that are available. Area estimates only and are subject to final survey.

SCALE

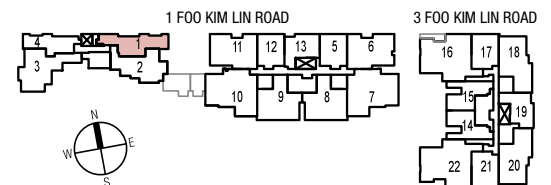

1 BEDROOM

TYPE A2

#02 - 04, #03 - 04, #04 - 04

41 sq m / 441 sq ft

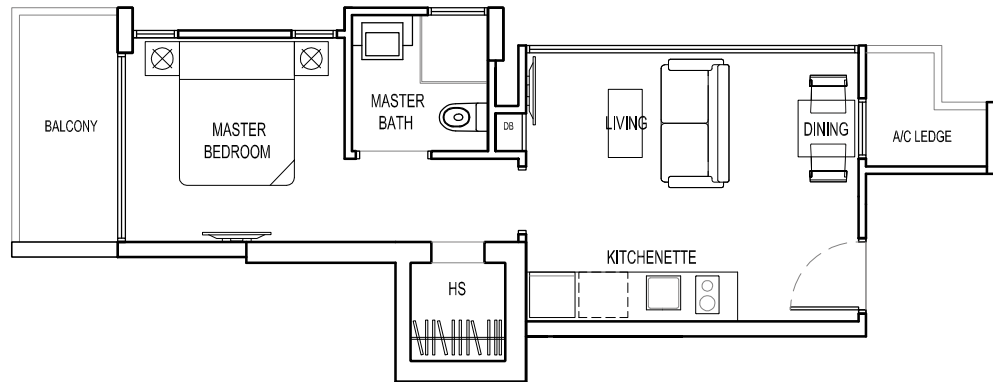

TYPE A2(P)

#01 - 04

41 sq m / 441 sq ft

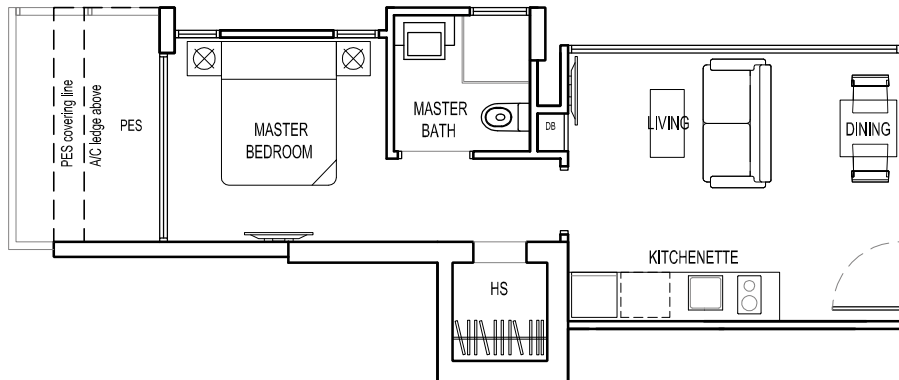

The plans are subject to change as may be required or approved by the relevant authorities.
These are not drawn to scale and are for the purpose of visual presentation of the different
layouts that are available. Area are estimates only and are subject to final survey.

SCALE

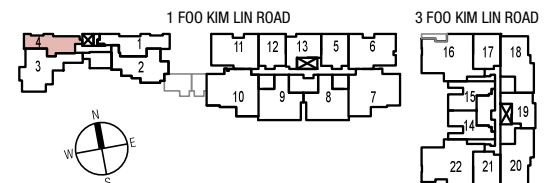
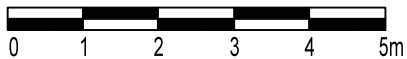

1 BEDROOM

TYPE A3

#02 – 12, #03 – 12, #04 – 12

Mirror Image

#02 – 05, #03 – 05, #04 – 05

#02 – 17, #03 – 17, #04 – 17

#02 – 21, #03 – 21, #04 – 21

41 sq m / 441 sq ft

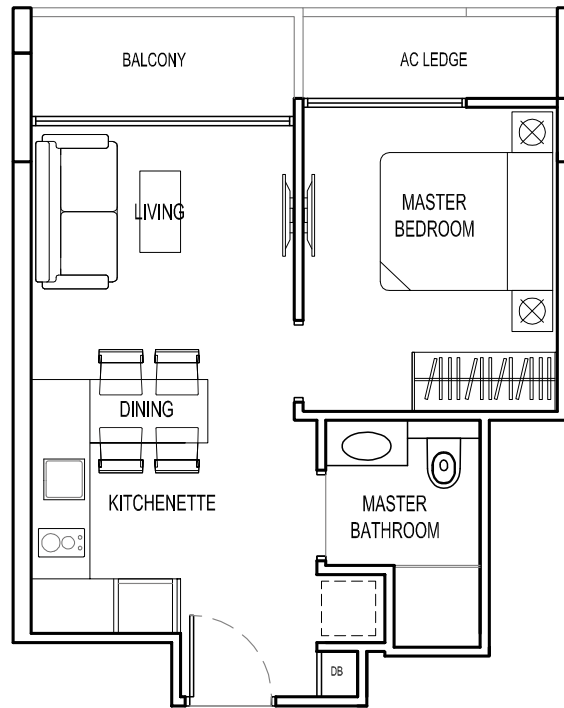

*The plans are subject to change as may be required or approved by the relevant authorities.
These are not drawn to scale and are for the purpose of visual presentation of the different
layouts that are available. Area are estimates only and are subject to final survey.*

SCALE

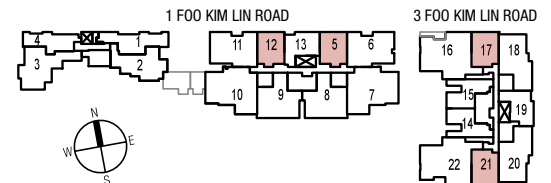

1 BEDROOM

TYPE A4(P)

#01 – 13, #01 – 19
42 sq m / 452 sq ft

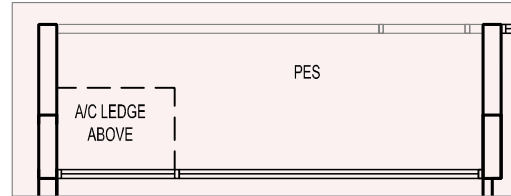

TYPE A4

#02 – 13, #03 – 13, #04 – 13
#02 – 19, #03 – 19, #04 – 19
40 sq m / 431 sq ft

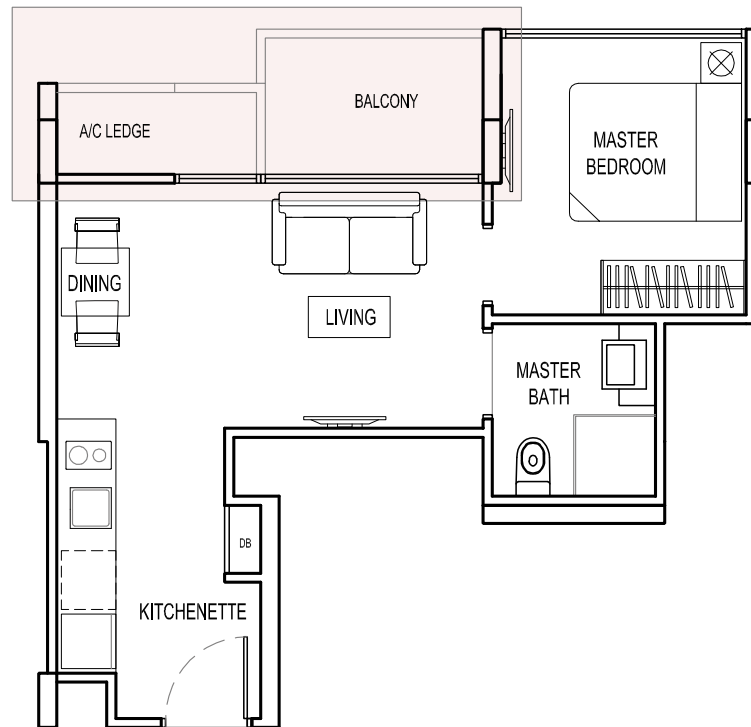

The plans are subject to change as may be required or approved by the relevant authorities.
These are not drawn to scale and are for the purpose of visual presentation of the different
layouts that are available. Area are estimates only and are subject to final survey.

SCALE

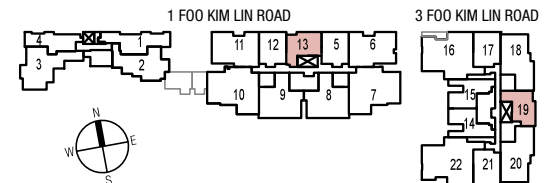

1 BEDROOM

TYPE A5

#02 – 14, #03 – 14, #04 – 14

Mirror Image

#02 – 15, #03 – 15, #04 – 15

43 sq m / 463 sq ft

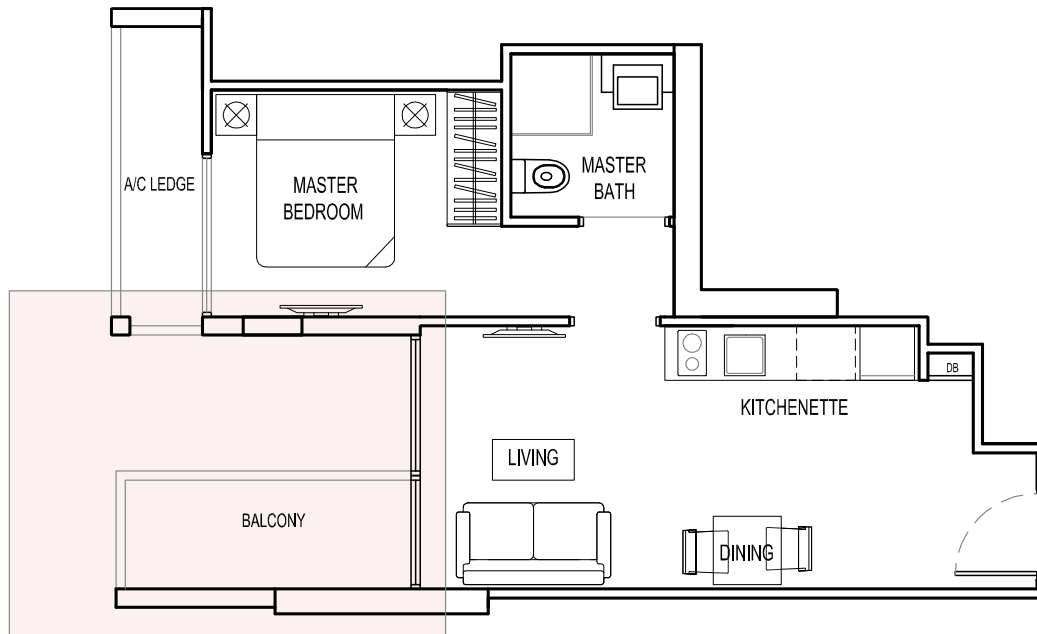

TYPE A5(P)

#01 – 14

44 sq m / 474 sq ft

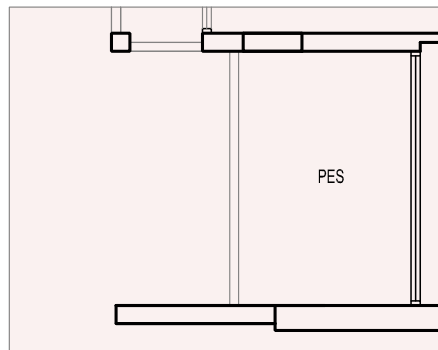

*The plans are subject to change as may be required or approved by the relevant authorities.
These are not drawn to scale and are for the purpose of visual presentation of the different
layouts that are available. Area are estimates only and are subject to final survey.*

SCALE

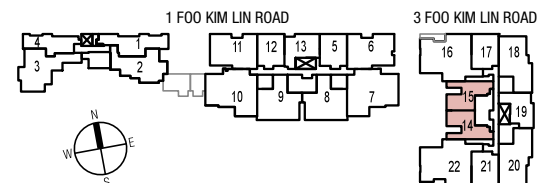

2 BEDROOM

TYPE B1

#03 - 02, #04 - 02
66 sq m / 710 sq ft

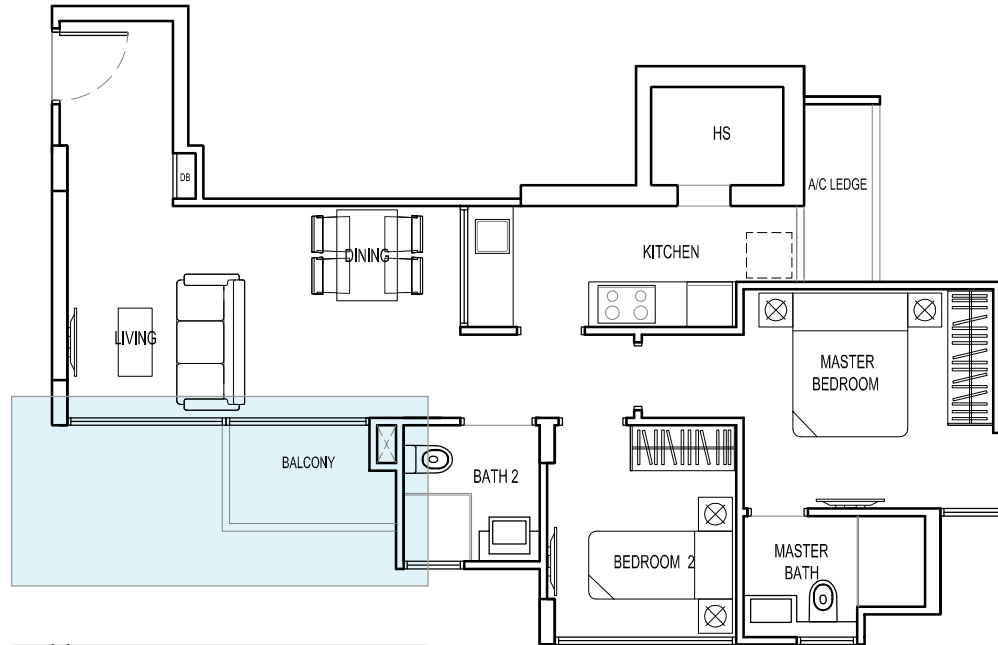

TYPE B1(P)

#01 - 02
68 sq m / 732 sq ft

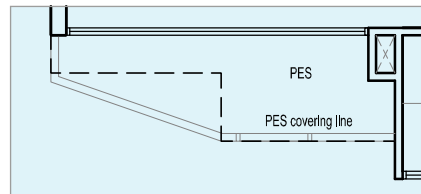

The plans are subject to change as may be required or approved by the relevant authorities.
These are not drawn to scale and are for the purpose of visual presentation of the different
layouts that are available. Area are estimates only and are subject to final survey.

SCALE

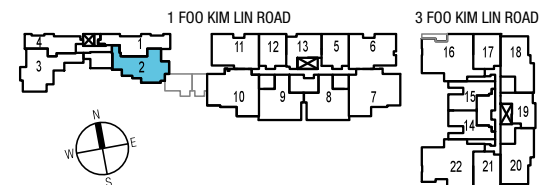
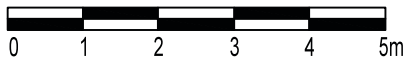

2 BEDROOM

TYPE B1(PP)

#02 – 02

90 sq m / 969 sq ft

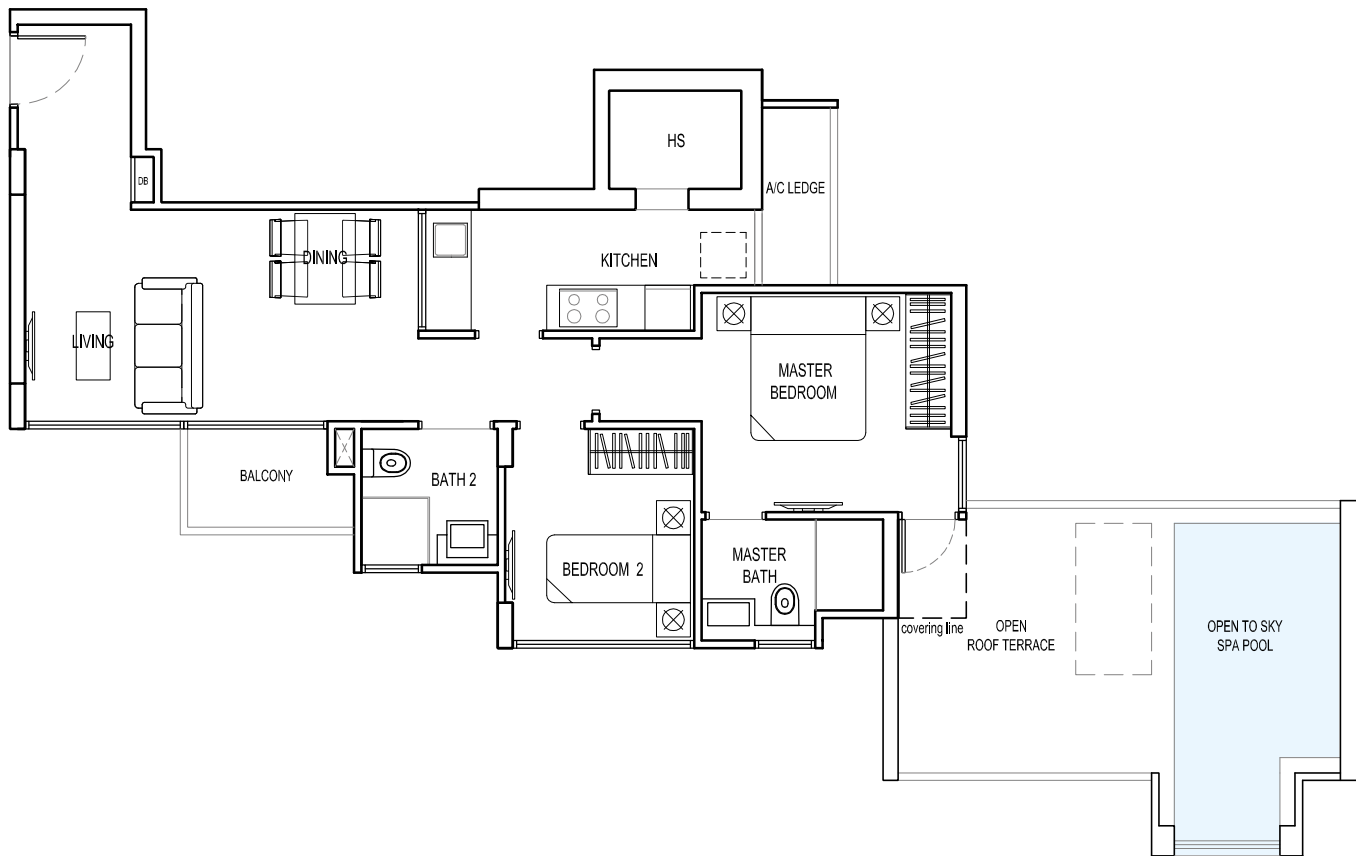

The plans are subject to change as may be required or approved by the relevant authorities. These are not drawn to scale and are for the purpose of visual presentation of the different layouts that are available. Area estimates only and are subject to final survey.

SCALE

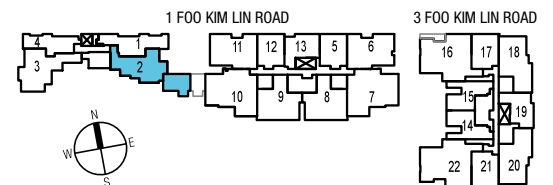
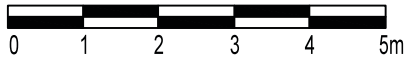

2 BEDROOM

TYPE B2

#02 - 03, #03 - 03, #04 - 03

72 sq m / 775 sq ft

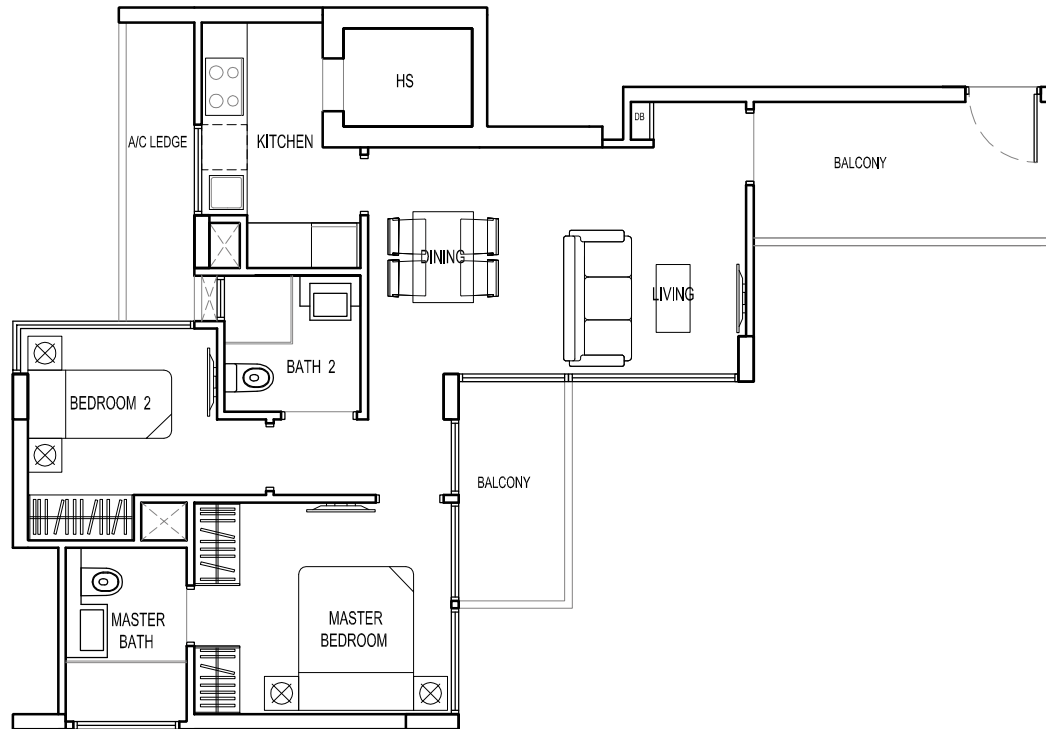

The plans are subject to change as may be required or approved by the relevant authorities. These are not drawn to scale and are for the purpose of visual presentation of the different layouts that are available. Area are estimates only and are subject to final survey.

SCALE

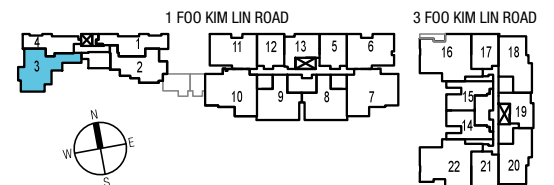

2 BEDROOM

TYPE B3

#02 – 09, #03 – 09, #04 – 09

Mirror Image

#02 – 08, #03 – 08, #04 – 08

68 sq m / 732 sq ft

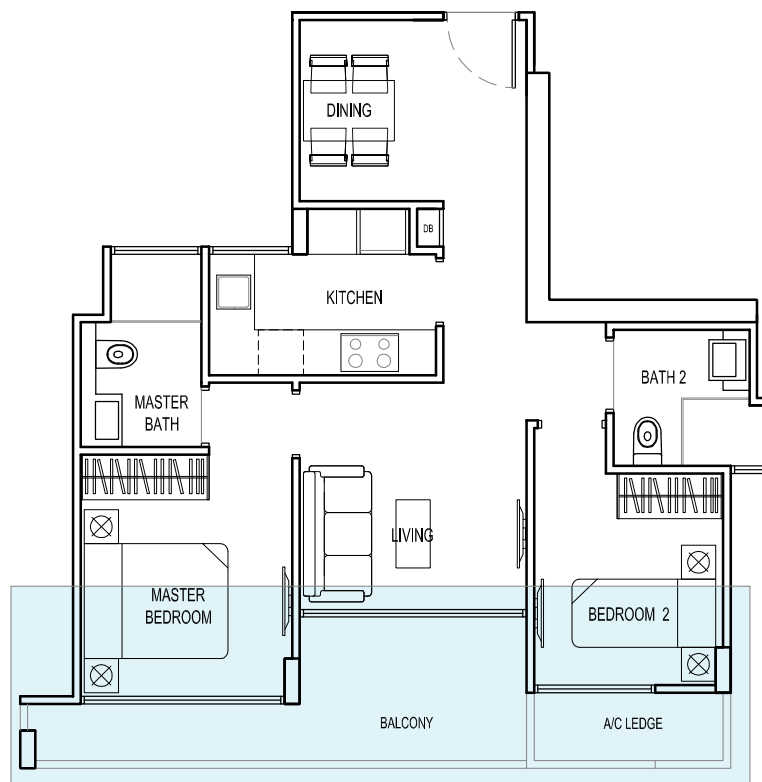

TYPE B3(P)

Mirror Image

#01 – 08

68 sq m / 732 sq ft

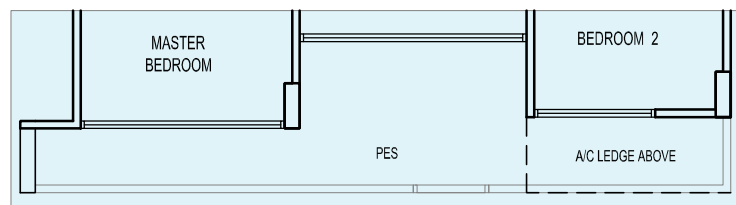

The plans are subject to change as may be required or approved by the relevant authorities.
These are not drawn to scale and are for the purpose of visual presentation of the different
layouts that are available. Area estimates only and are subject to final survey.

SCALE

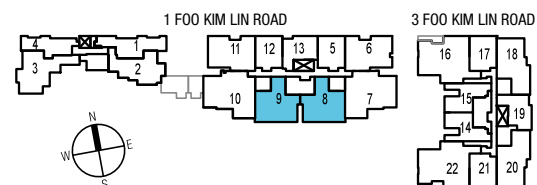

2 BEDROOM

TYPE B4

#02 – 18, #03 – 18, #04 – 18

Mirror Image

#02 – 20, #03 – 20, #04 – 20

71 sq m / 764 sq ft

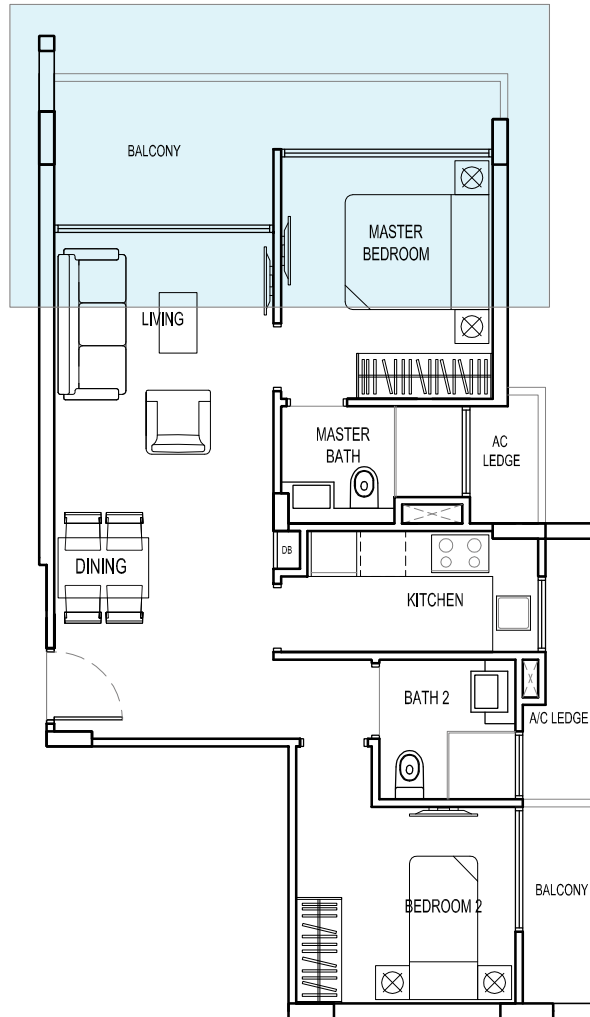

TYPE B4(P1)

#01 – 18

74 sq m / 797 sq ft

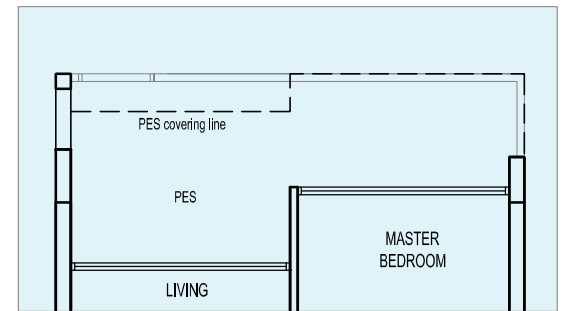

TYPE B4(P)

Mirror Image

#01 – 20

78 sq m / 840 sq ft

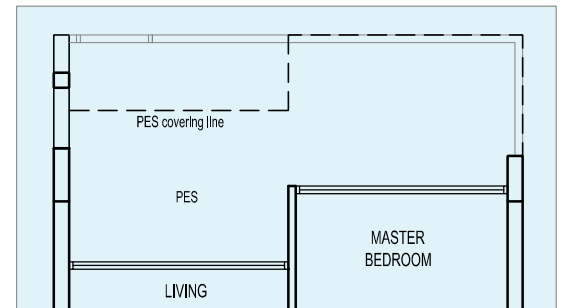

The plans are subject to change as may be required or approved by the relevant authorities. These are not drawn to scale and are for the purpose of visual presentation of the different layouts that are available. Area are estimates only and are subject to final survey.

SCALE

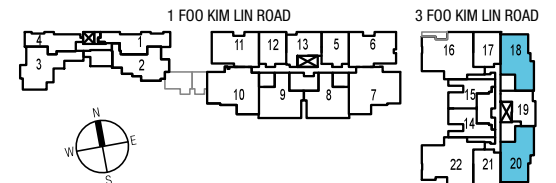
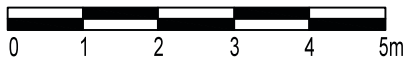

2 BEDROOM + STUDY

TYPE BS

#02 – 06, #03 – 06, #04 – 06

Mirror Image

#02 – 11, #03 – 11, #04 – 11

72 sq m / 775 sq ft

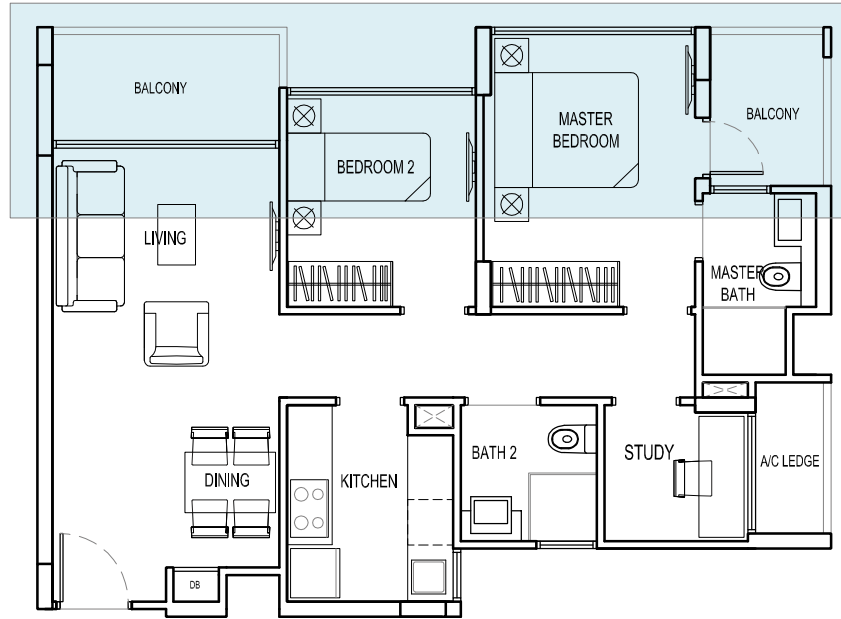

TYPE BS(P)

#01 – 06

74 sq m / 797 sq ft

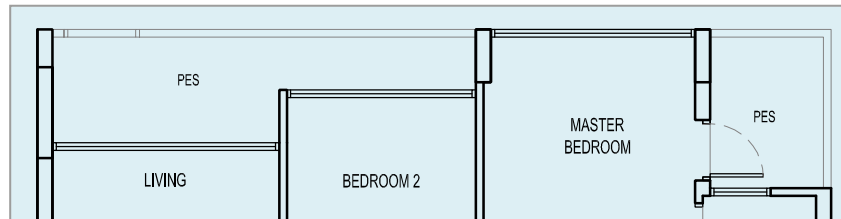

The plans are subject to change as may be required or approved by the relevant authorities.
These are not drawn to scale and are for the purpose of visual presentation of the different
layouts that are available. Area estimates only and are subject to final survey.

SCALE

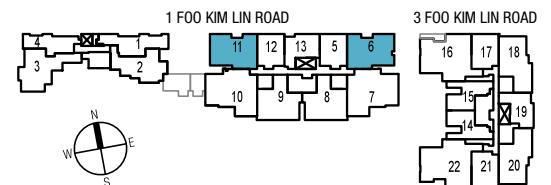
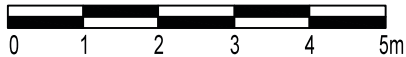

3 BEDROOM

TYPE C1

#03 – 07, #04 – 07

Mirror Image

#03 – 10, #04 – 10

96 sq m / 1,033 sq ft

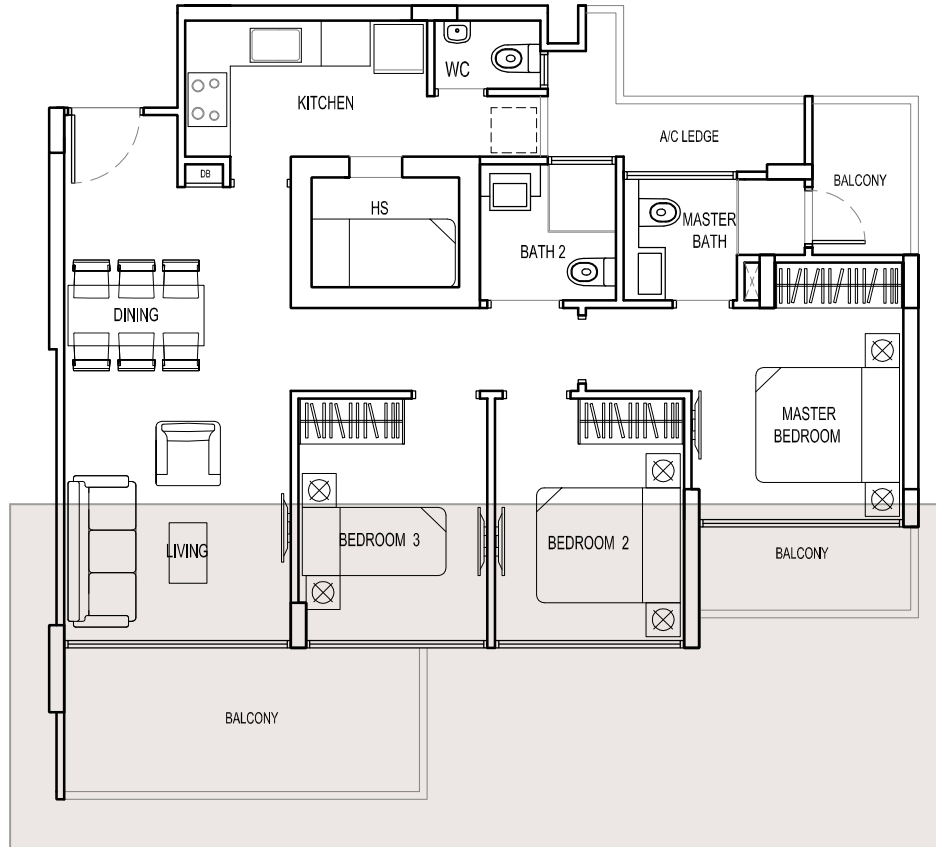

TYPE C4

#02 – 07

103 sq m / 1,109 sq ft

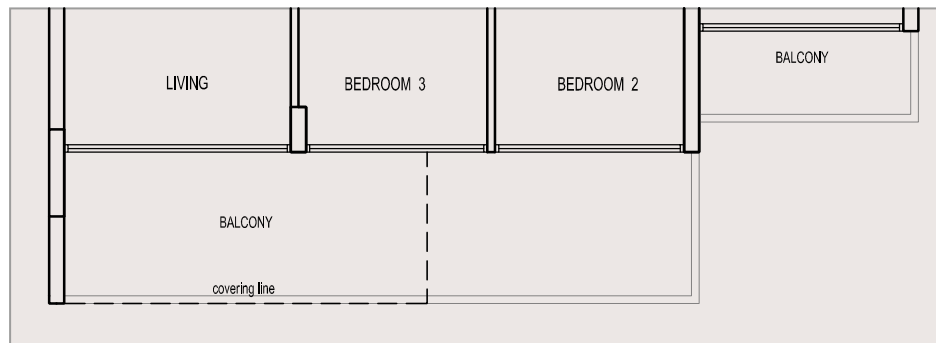

The plans are subject to change as may be required or approved by the relevant authorities. These are not drawn to scale and are for the purpose of visual presentation of the different layouts that are available. Area are estimates only and are subject to final survey.

SCALE

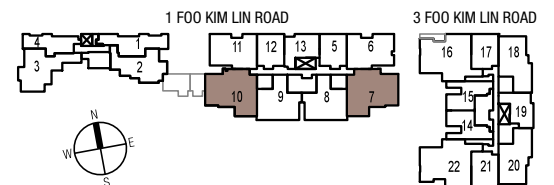
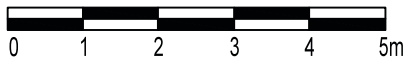

3 BEDROOM

TYPE C1(P)

#01 – 07

115 sq m / 1,238 sq ft

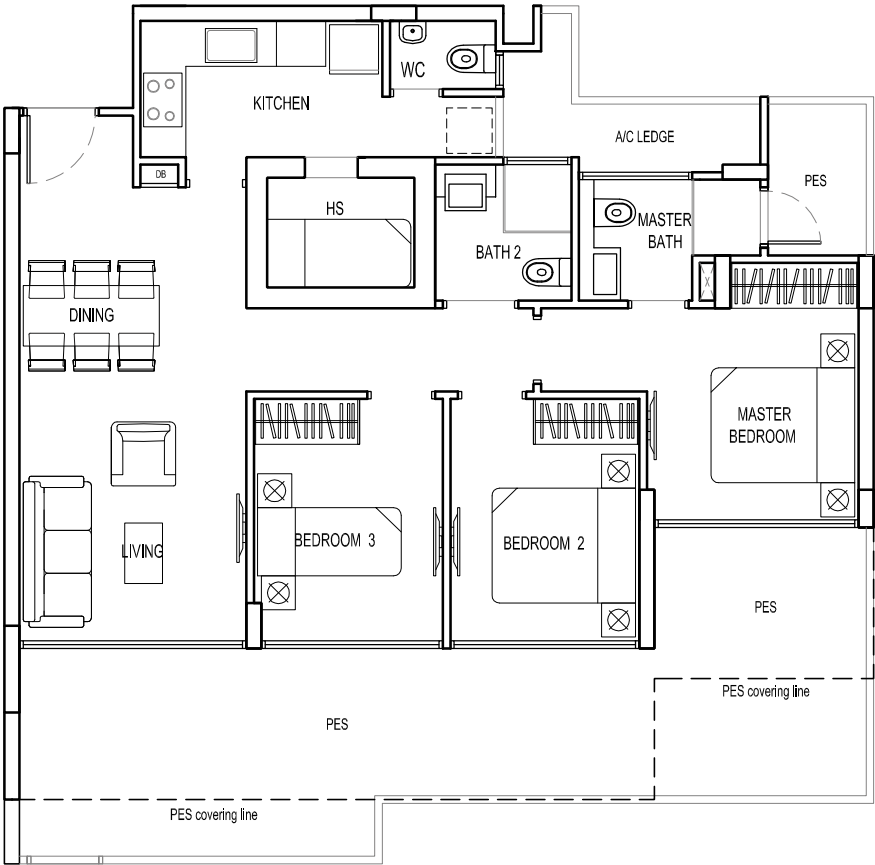

The plans are subject to change as may be required or approved by the relevant authorities. These are not drawn to scale and are for the purpose of visual presentation of the different layouts that are available. Area are estimates only and are subject to final survey.

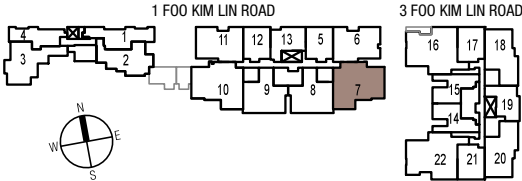

3 BEDROOM

TYPE C1(PP)

#02 - 10

110 sq m / 1,184 sq ft

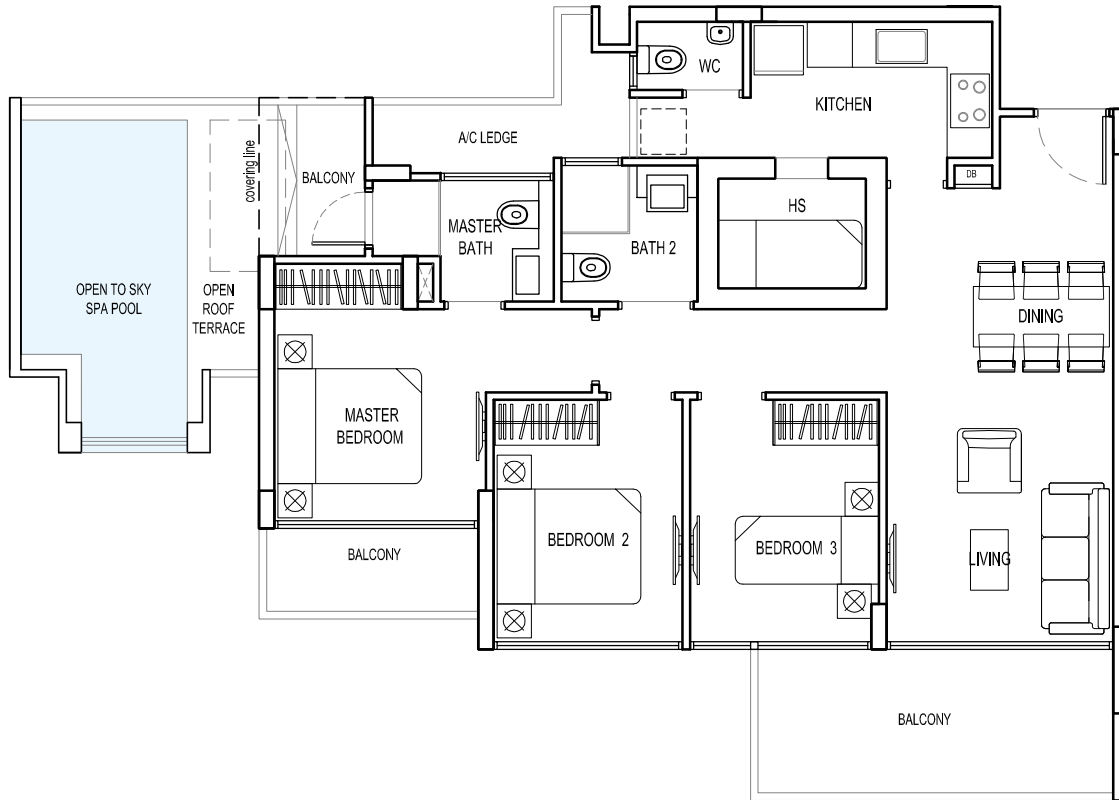

The plans are subject to change as may be required or approved by the relevant authorities.
These are not drawn to scale and are for the purpose of visual presentation of the different
layouts that are available. Area are estimates only and are subject to final survey.

SCALE

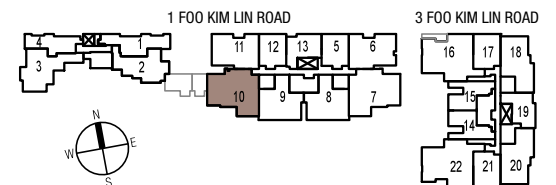

3 BEDROOM

TYPE C3

#02 – 16
107 sq m / 1,152 sq ft

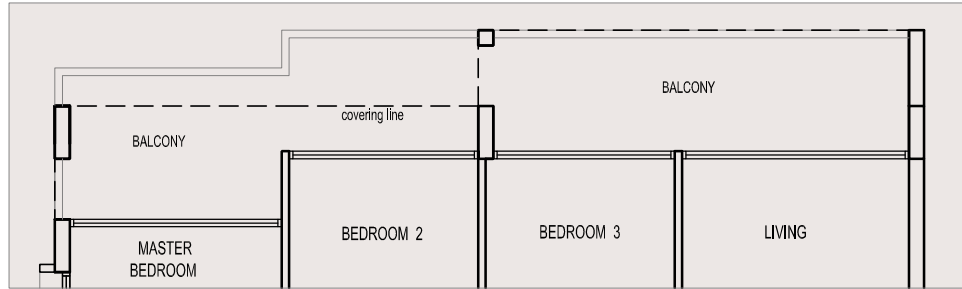

TYPE C2

#03 – 16, #04 – 16

Mirror Image

#02 – 22, #03 – 22, #04 – 22
102 sq m / 1,098 sq ft

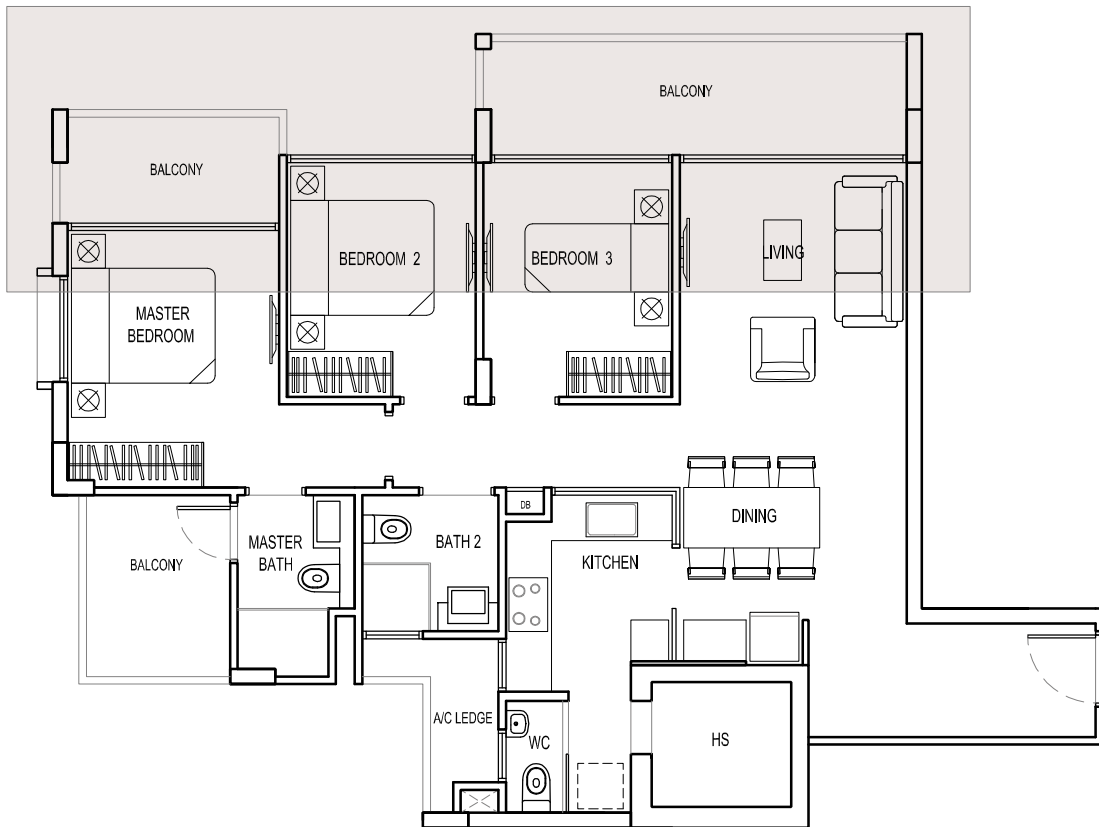

The plans are subject to change as may be required or approved by the relevant authorities.
These are not drawn to scale and are for the purpose of visual presentation of the different
layouts that are available. Area estimates only and are subject to final survey.

SCALE

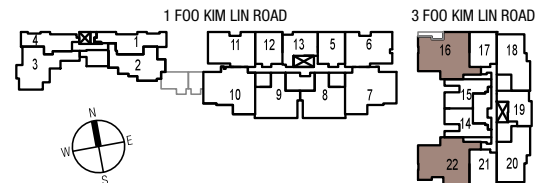
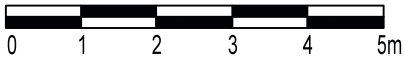

3 BEDROOM

TYPE C2(P)

#01 - 16

119 sq m / 1,281 sq ft

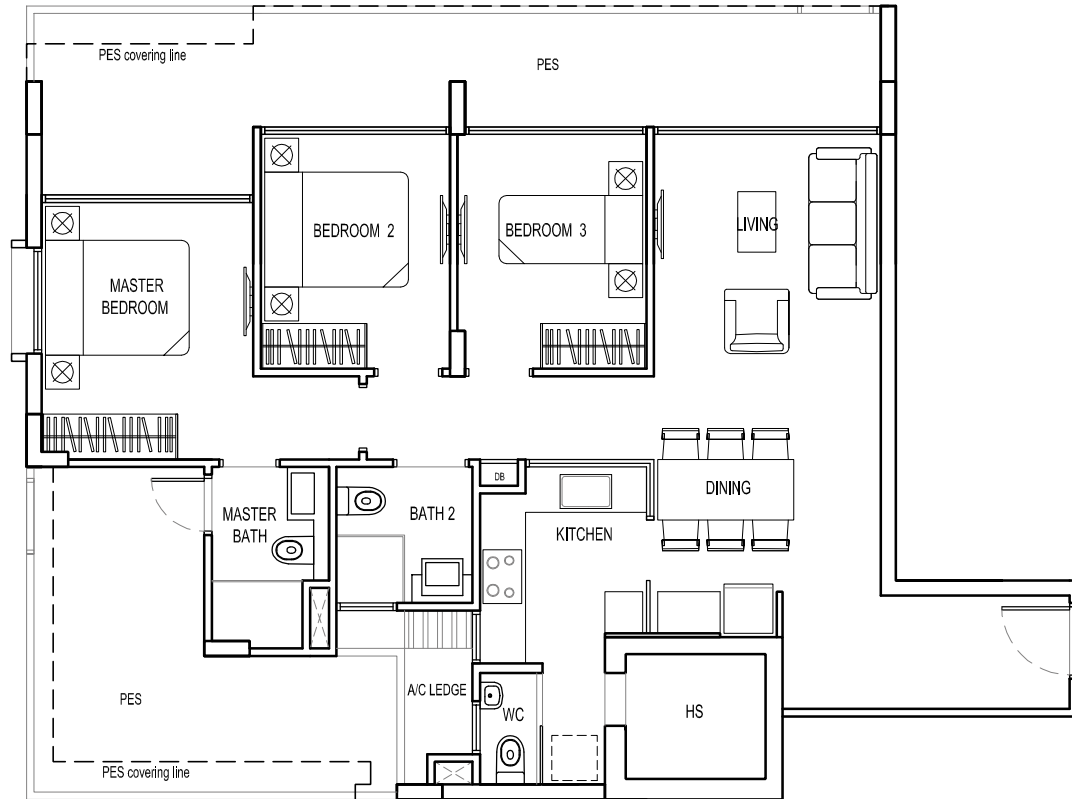

The plans are subject to change as may be required or approved by the relevant authorities.
These are not drawn to scale and are for the purpose of visual presentation of the different
layouts that are available. Area are estimates only and are subject to final survey.

SCALE

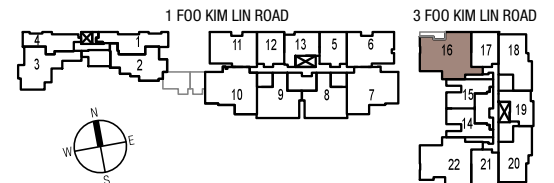

3 BEDROOM

TYPE C2(P1)

#01 - 22

122 sq m / 1,313 sq ft

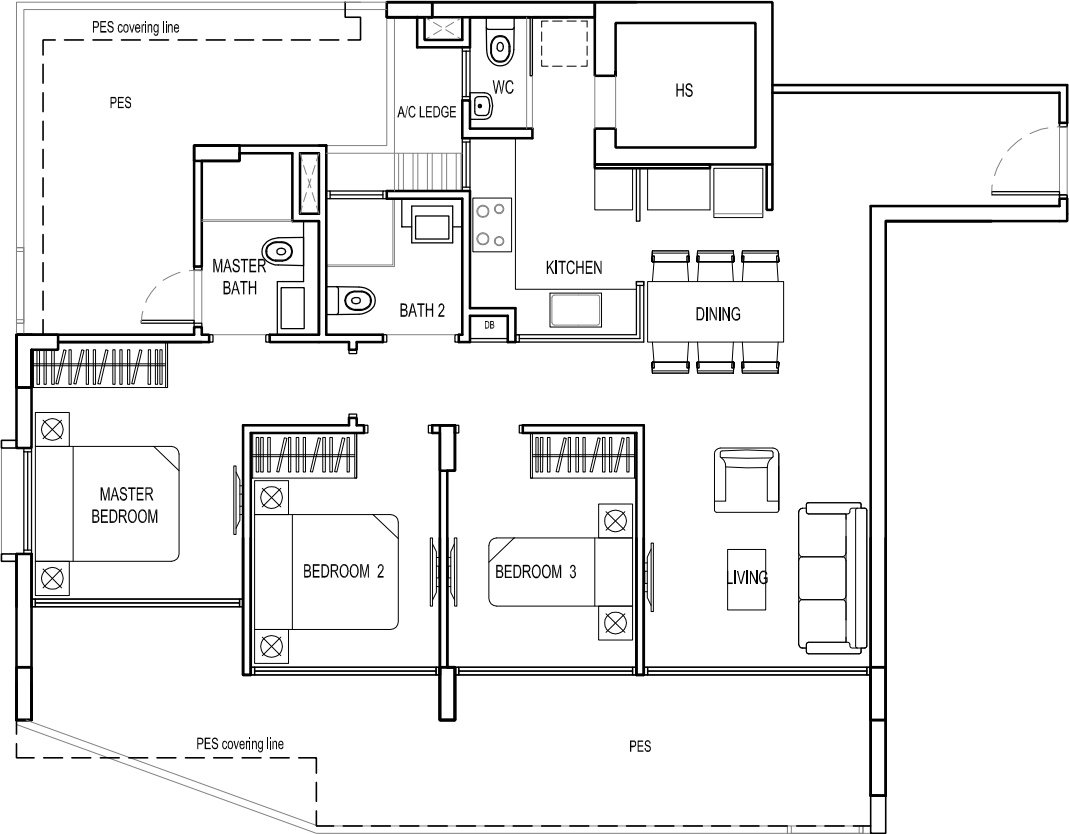

The plans are subject to change as may be required or approved by the relevant authorities. These are not drawn to scale and are for the purpose of visual presentation of the different layouts that are available. Area estimates only and are subject to final survey.

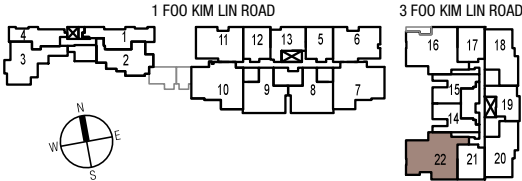
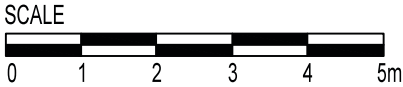

PENTHOUSE (1 BEDROOM + STUDY)

TYPE PH1

#05 - 01

80 sq m / 861 sq ft

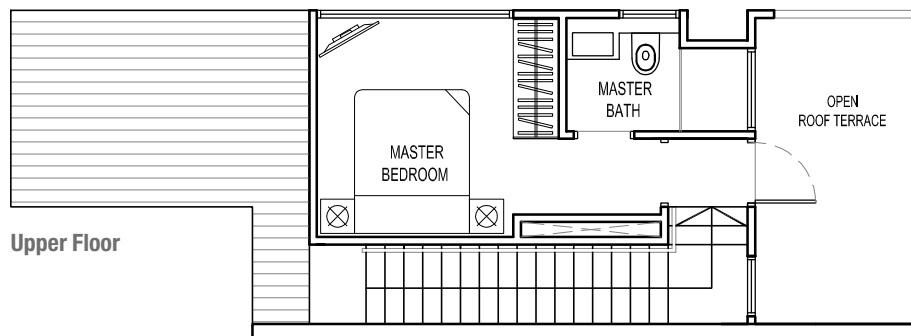
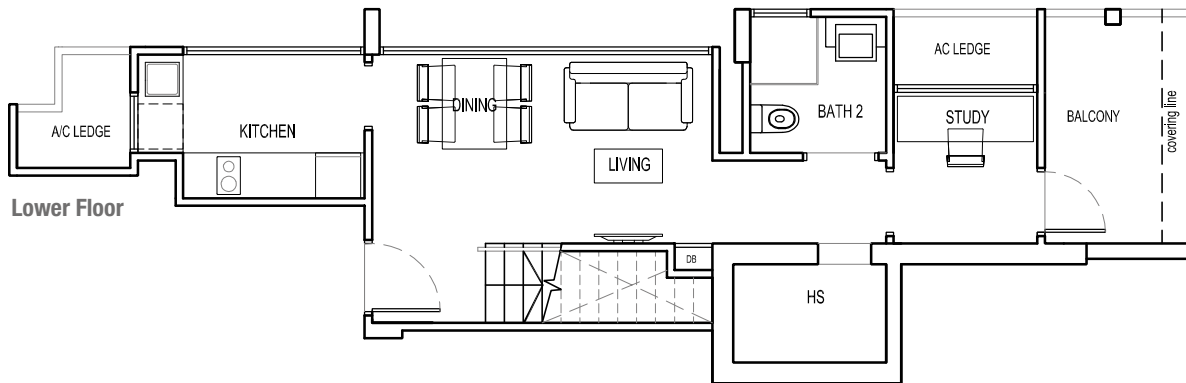

The plans are subject to change as may be required or approved by the relevant authorities.
These are not drawn to scale and are for the purpose of visual presentation of the different
layouts that are available. Area are estimates only and are subject to final survey.

SCALE

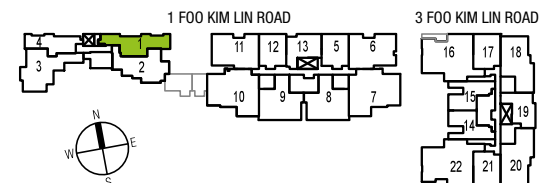

PENTHOUSE (1 BEDROOM + STUDY)

TYPE PH2

#05 – 04
76 sq m / 818 sq ft

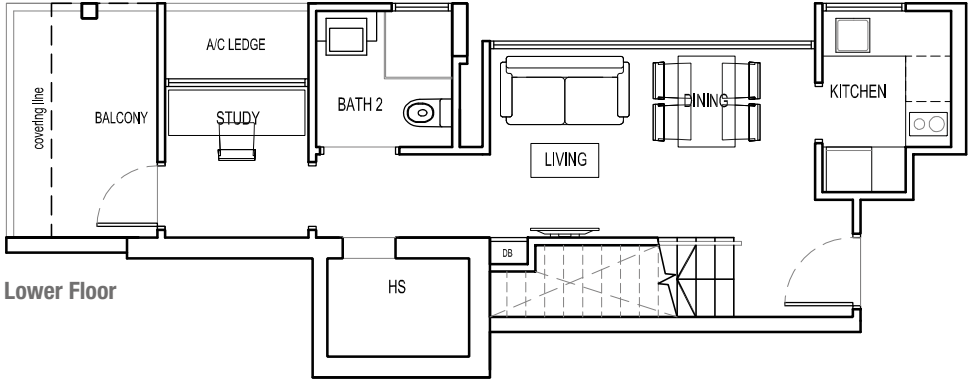

Lower Floor

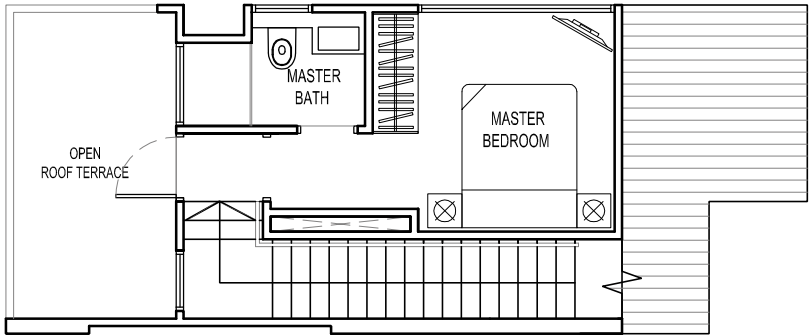

Upper Floor

The plans are subject to change as may be required or approved by the relevant authorities. These are not drawn to scale and are for the purpose of visual presentation of the different layouts that are available. Area are estimates only and are subject to final survey.

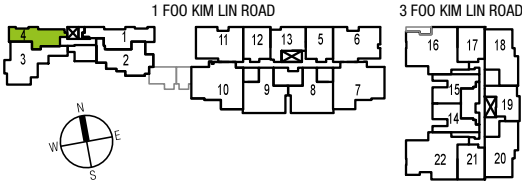
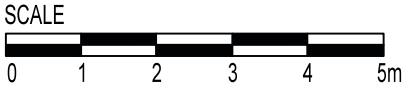

PENTHOUSE (1 BEDROOM + STUDY)

TYPE PH3

#05 – 12

Mirror Image

#05 – 05, #05 – 17, #05 – 21

78 sq m / 840 sq ft

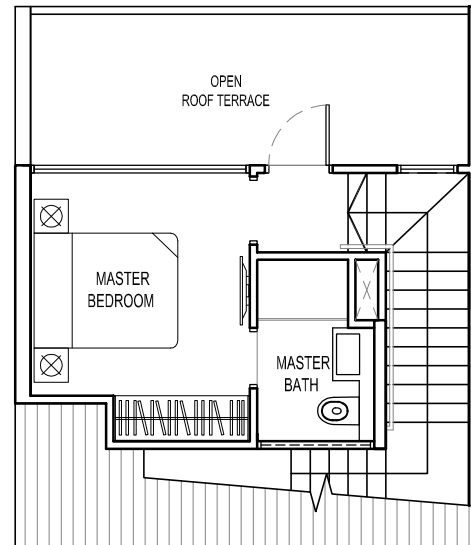
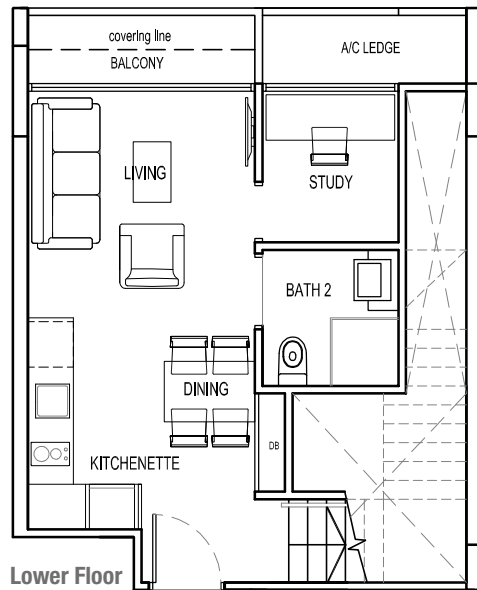

Upper Floor

The plans are subject to change as may be required or approved by the relevant authorities. These are not drawn to scale and are for the purpose of visual presentation of the different layouts that are available. Area are estimates only and are subject to final survey.

SCALE

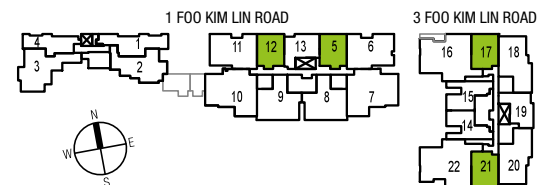
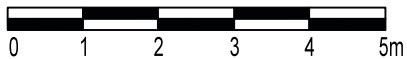

PENTHOUSE (1 BEDROOM + STUDY)



TYPE PH4

#05 – 13, #05 – 19
78 sq m / 840 sq ft

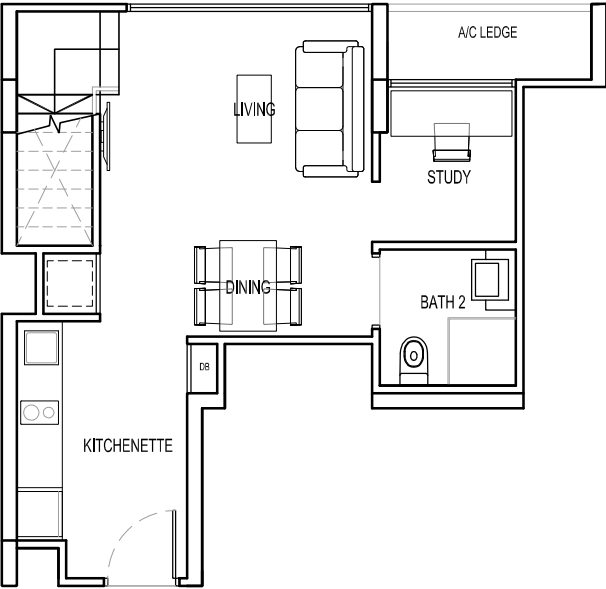

Lower Floor

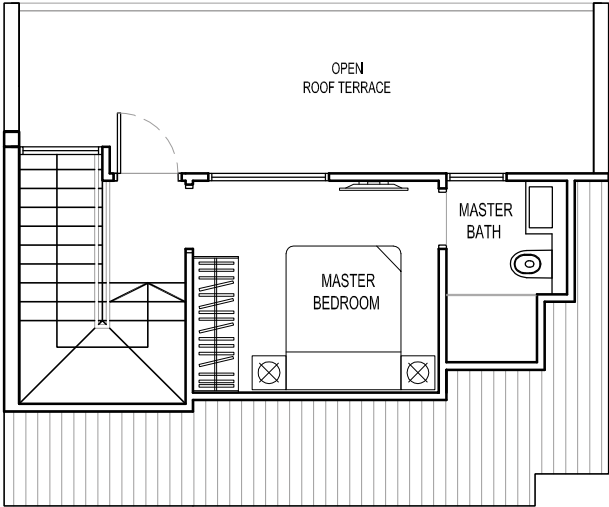

Upper Floor

The plans are subject to change as may be required or approved by the relevant authorities. These are not drawn to scale and are for the purpose of visual presentation of the different layouts that are available. Area estimates only and are subject to final survey.

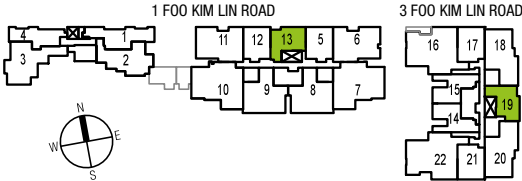
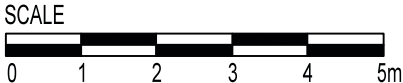

PENTHOUSE (1 BEDROOM + STUDY)

TYPE PH5

#05 – 14

Mirror Image

#05 – 15

90 sq m / 969 sq ft

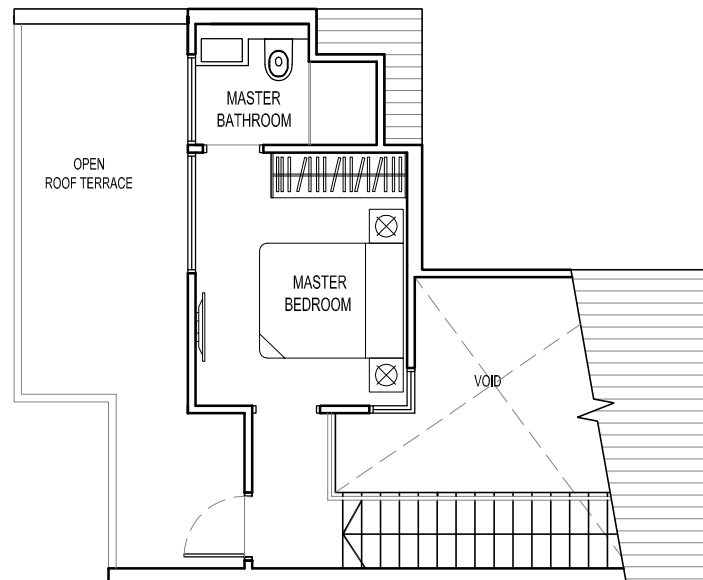
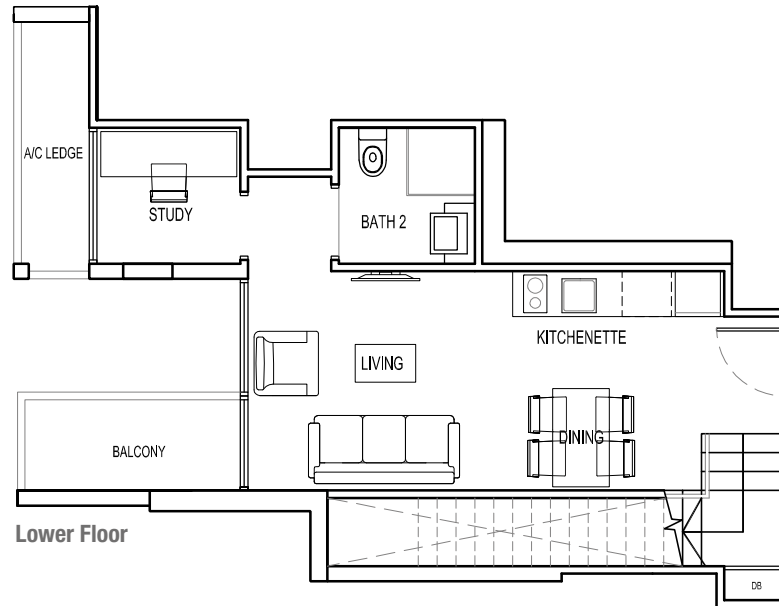

The plans are subject to change as may be required or approved by the relevant authorities. These are not drawn to scale and are for the purpose of visual presentation of the different layouts that are available. Area are estimates only and are subject to final survey.

SCALE

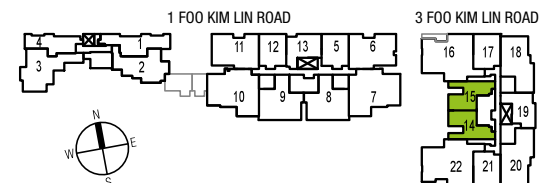
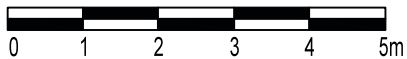

PENTHOUSE (2 BEDROOM + STUDY)

TYPE PH6
 #05 - 02
 118 sq m / 1,270 sq ft

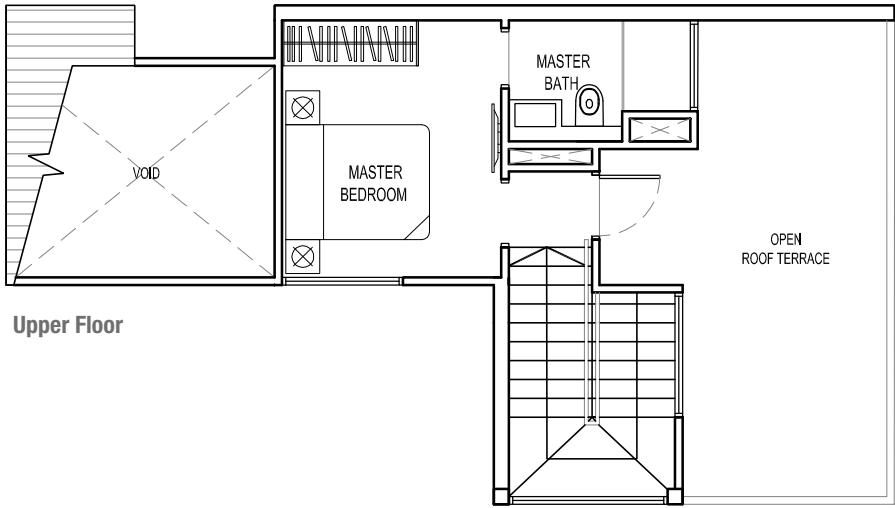
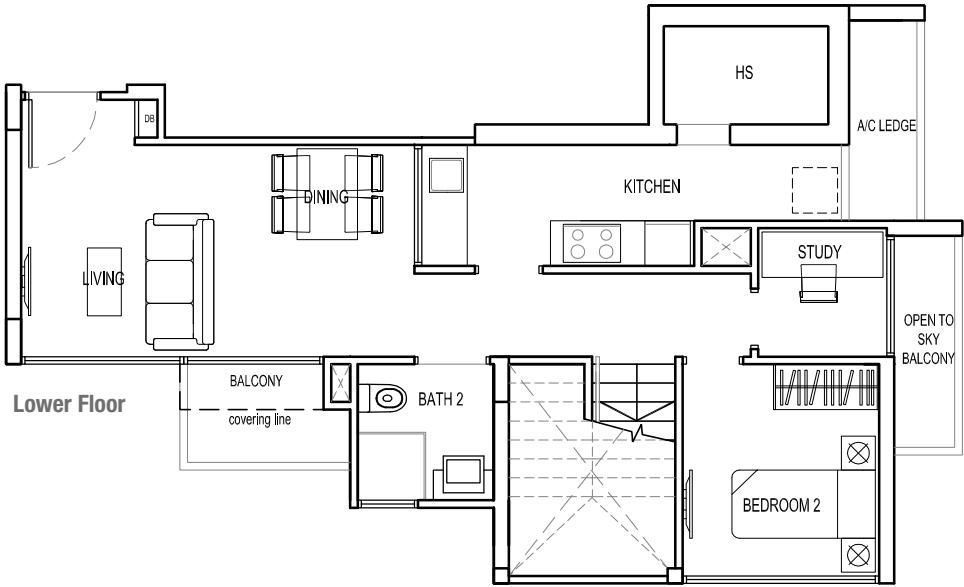

The plans are subject to change as may be required or approved by the relevant authorities. These are not drawn to scale and are for the purpose of visual presentation of the different layouts that are available. Area are estimates only and are subject to final survey.

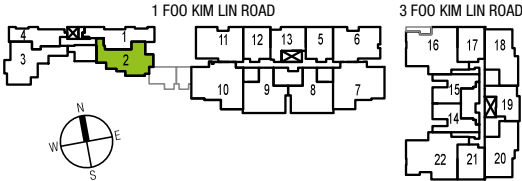
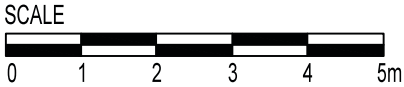

PENTHOUSE (2 BEDROOM + STUDY)

TYPE PH7

#05 - 03

123 sq m / 1,324 sq ft

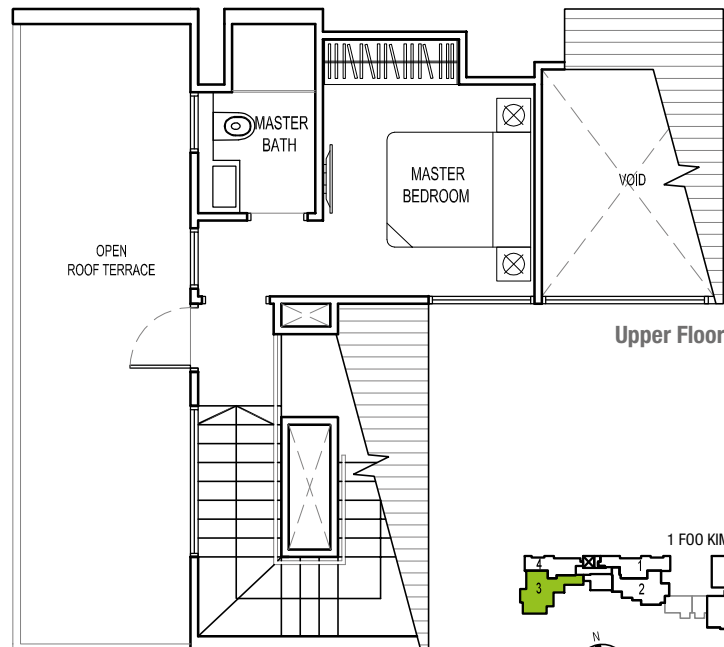
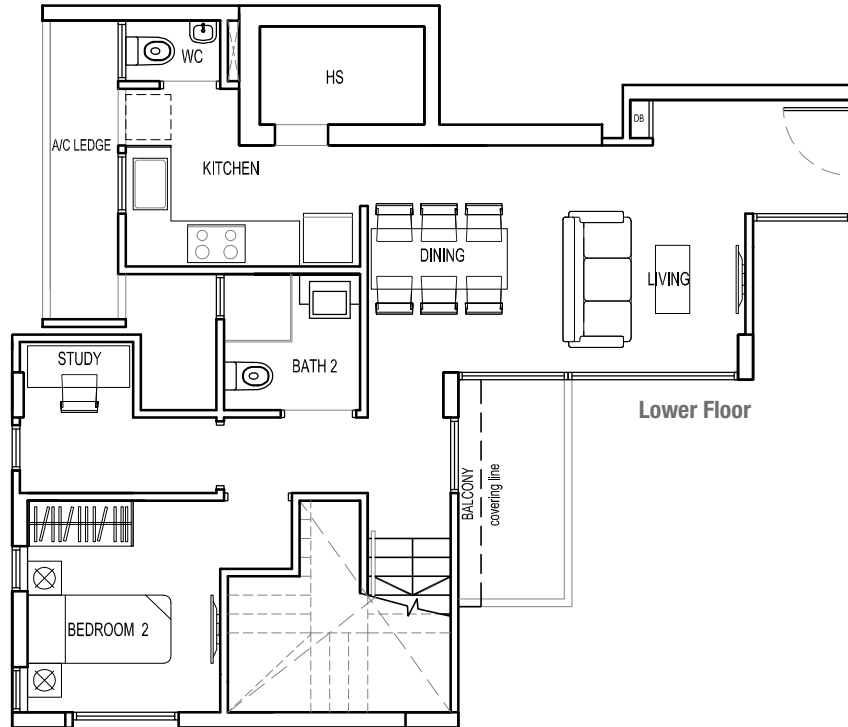

The plans are subject to change as may be required or approved by the relevant authorities. These are not drawn to scale and are for the purpose of visual presentation of the different layouts that are available. Area are estimates only and are subject to final survey.

SCALE

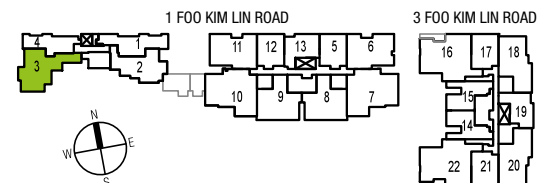
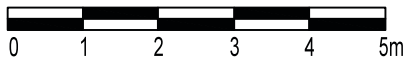

PENTHOUSE (2 BEDROOM + STUDY)

TYPE PH8

#05 – 09

Mirror Image

#05 – 08

120 sq m / 1,292 sq ft

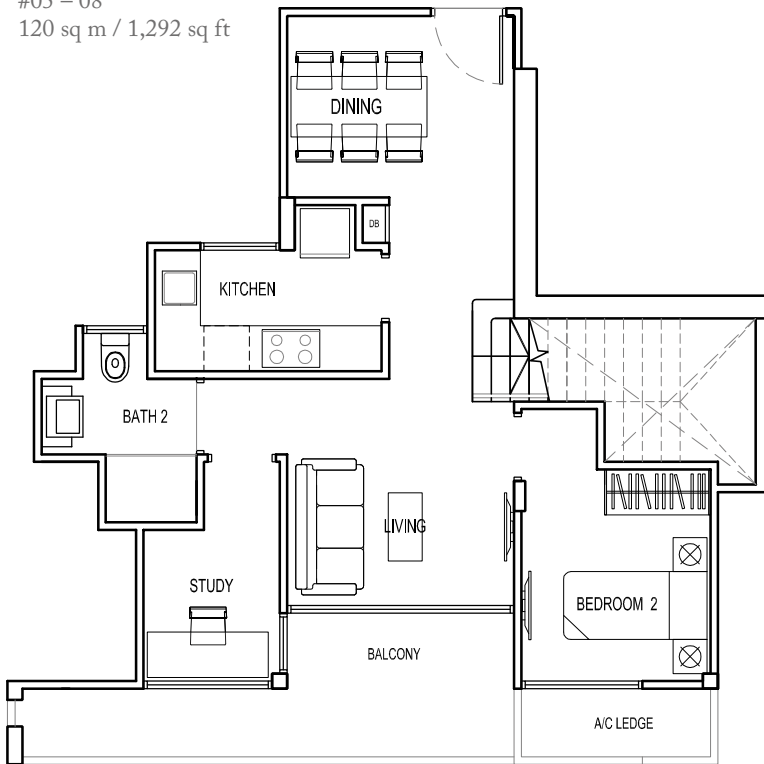

Lower Floor

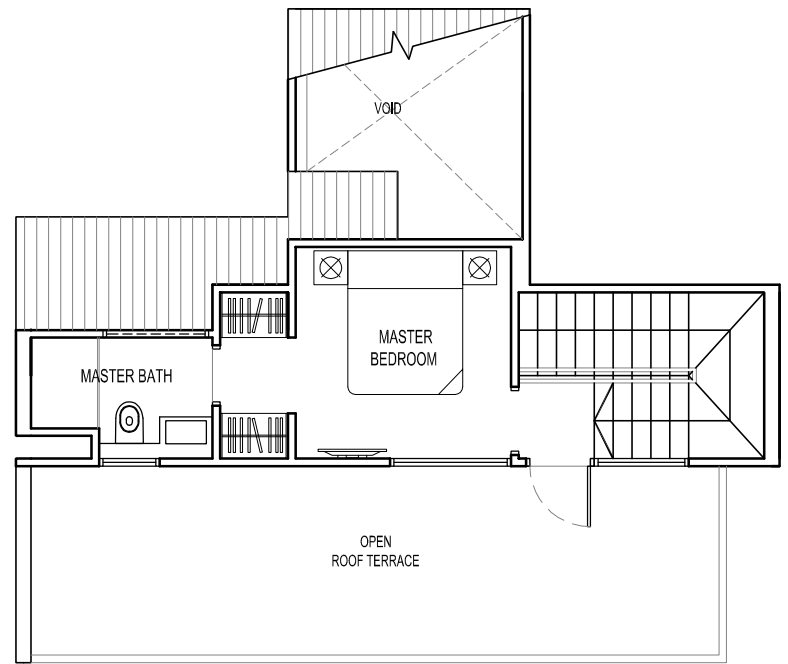

Upper Floor

The plans are subject to change as may be required or approved by the relevant authorities. These are not drawn to scale and are for the purpose of visual presentation of the different layouts that are available. Area estimates only and are subject to final survey.

SCALE

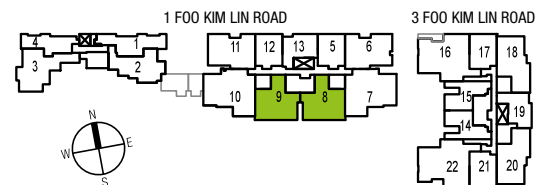

PENTHOUSE (2 BEDROOM + STUDY)

TYPE PH9

#05 - 18

Mirror Image

#05 - 20

111 sq m / 1,195 sq ft

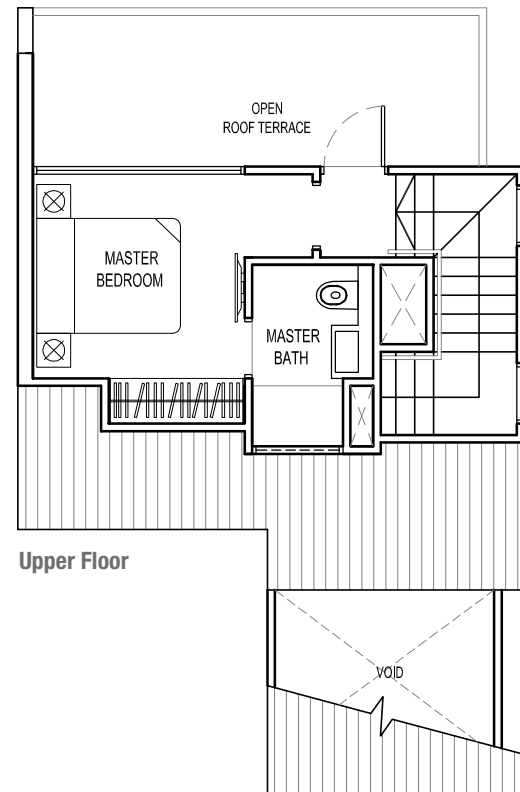
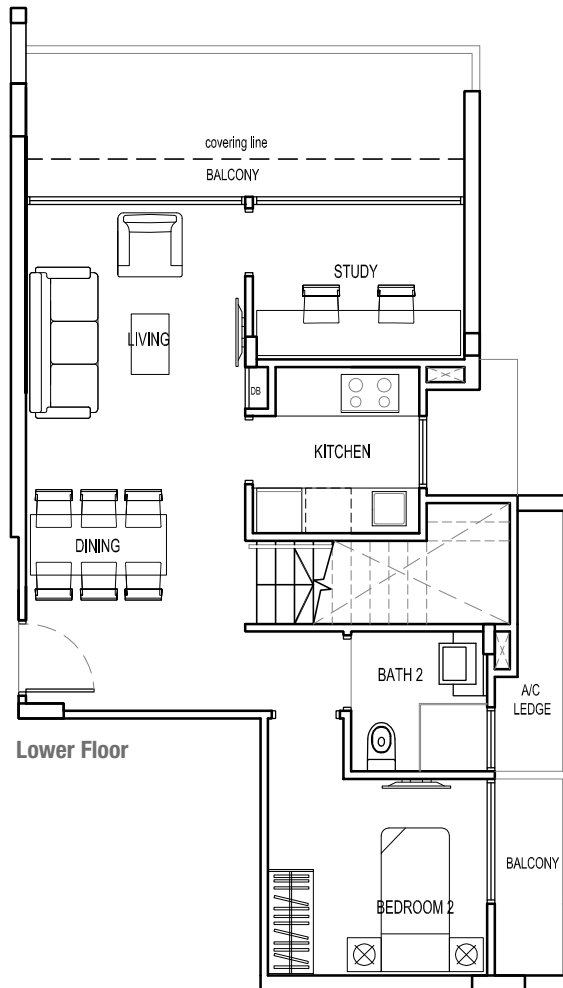

The plans are subject to change as may be required or approved by the relevant authorities. These are not drawn to scale and are for the purpose of visual presentation of the different layouts that are available. Area are estimates only and are subject to final survey.

SCALE

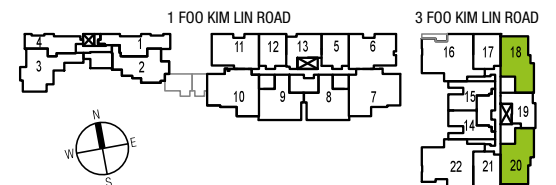
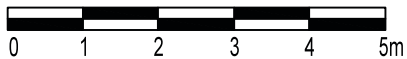

PENTHOUSE (3 BEDROOM + STUDY)

TYPE PH10

#05 – 11

Mirror Image

#05 – 06

137 sq m / 1,475 sq ft

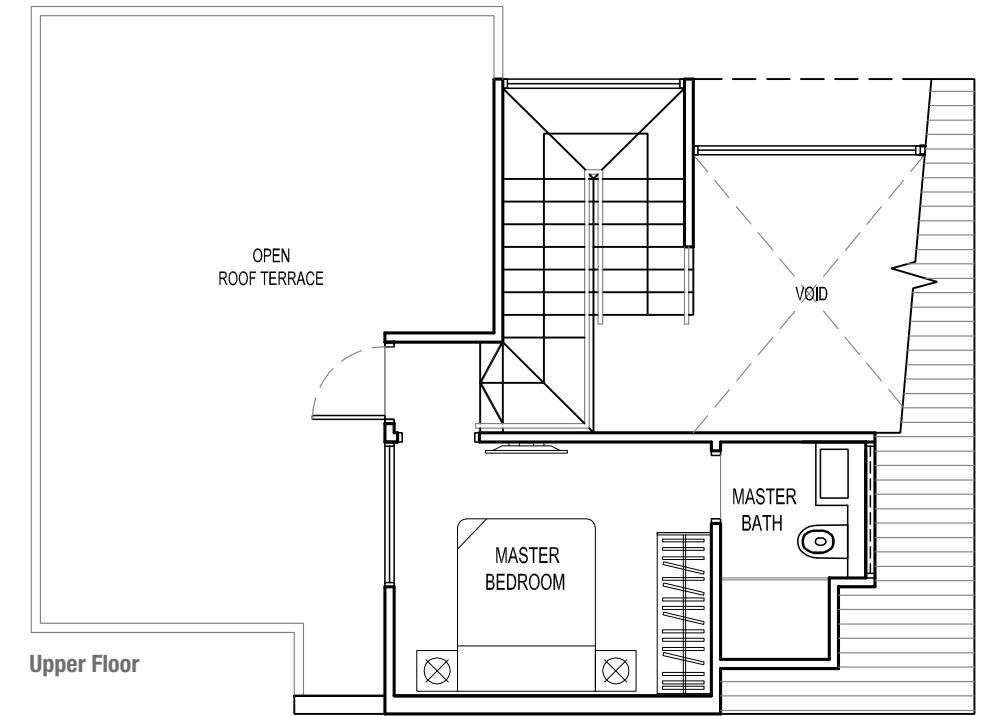
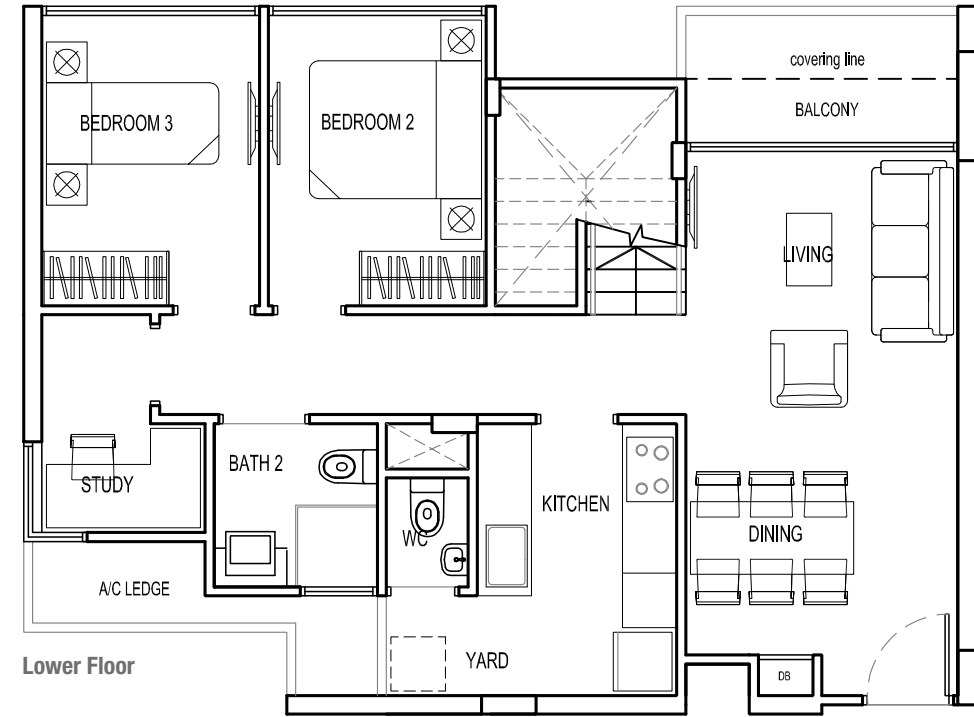

The plans are subject to change as may be required or approved by the relevant authorities. These are not drawn to scale and are for the purpose of visual presentation of the different layouts that are available. Area are estimates only and are subject to final survey.

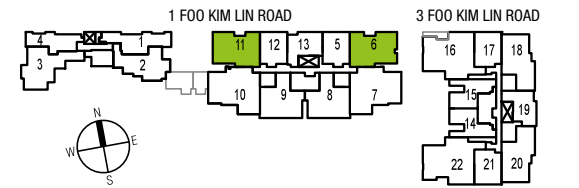
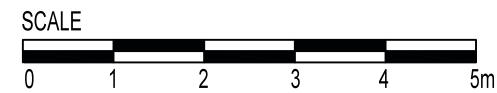

PENTHOUSE (3 BEDROOM + STUDY)

TYPE PH11

#05 – 10

Mirror Image

#05 – 07

169 sq m / 1,819 sq ft

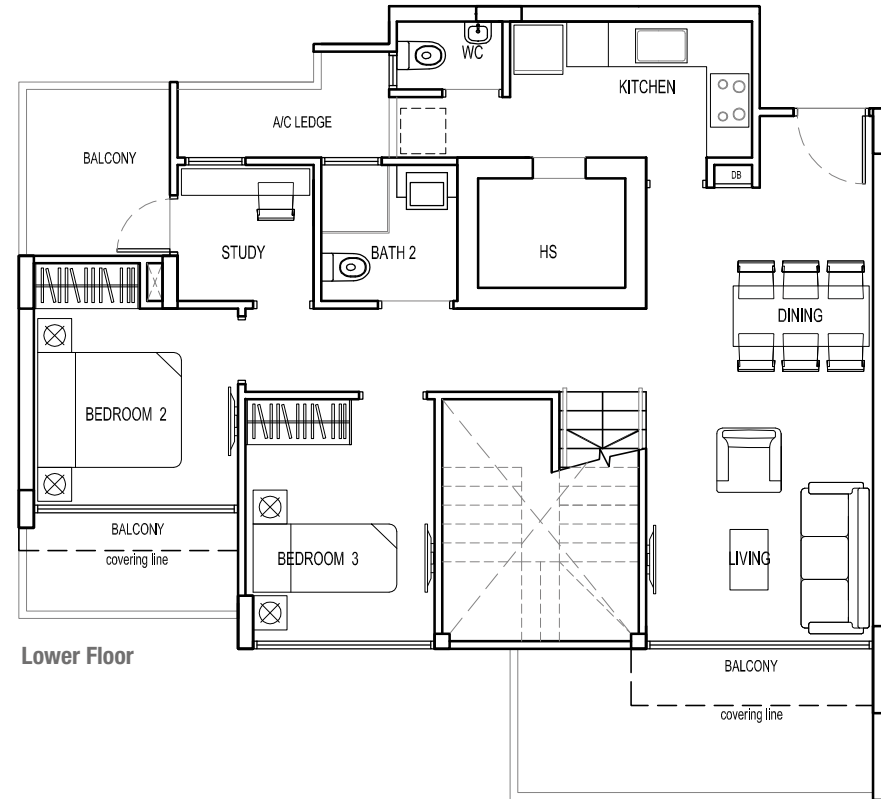

Lower Floor

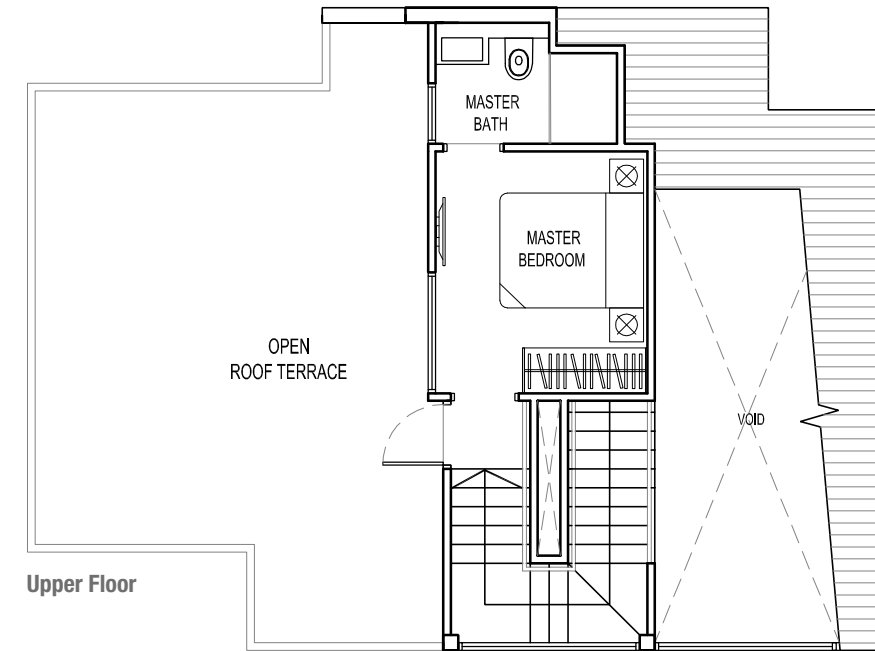

Upper Floor

The plans are subject to change as may be required or approved by the relevant authorities. These are not drawn to scale and are for the purpose of visual presentation of the different layouts that are available. Area are estimates only and are subject to final survey.

SCALE

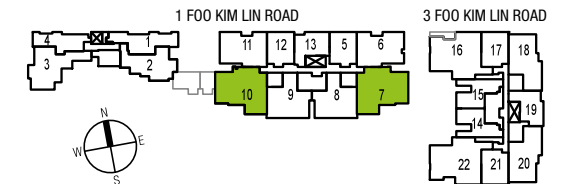

PENTHOUSE (3 BEDROOM + STUDY)

TYPE PH12

#05 – 16

Mirror Image

#05 – 22

169 sq m / 1,819 sq ft

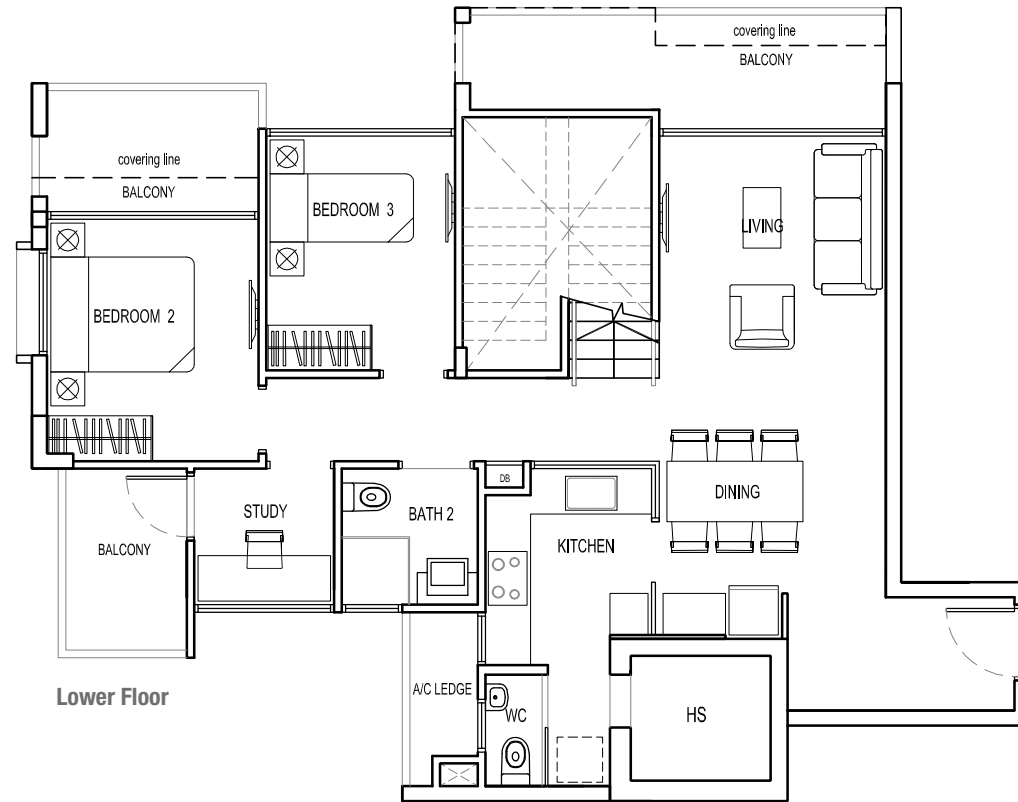

Lower Floor

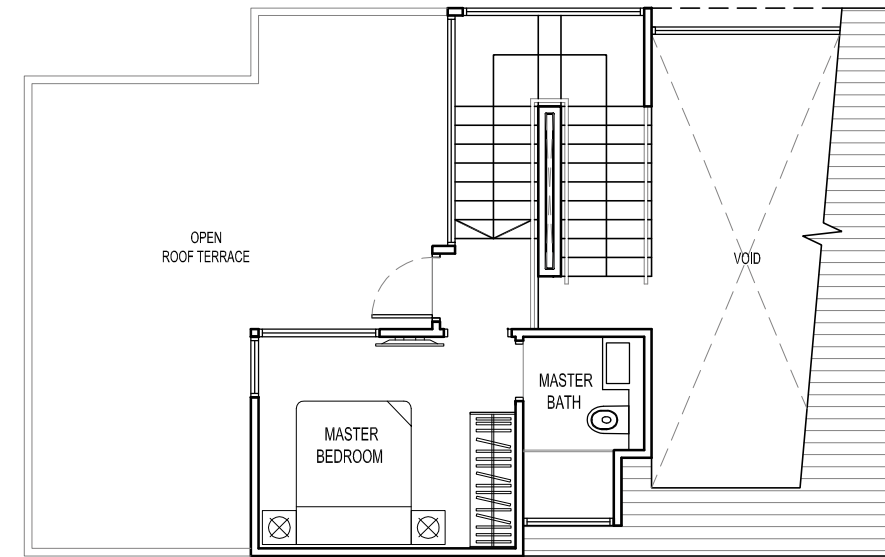

Upper Floor

The plans are subject to change as may be required or approved by the relevant authorities. These are not drawn to scale and are for the purpose of visual presentation of the different layouts that are available. Area are estimates only and are subject to final survey.

SCALE

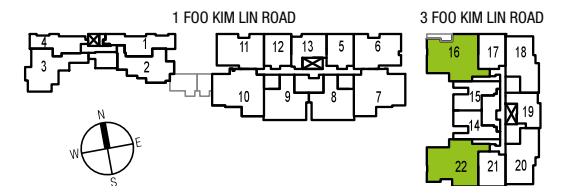

1. Foundation

Reinforced concrete Piled foundation and/or other approved foundation to Engineer's design.

2. Substructure & Superstructure

Reinforced Concrete Framework and/or Steel Frame.

3. Wall

External : Common clay bricks and/or precast panel and/or reinforced concrete.

Internal : Common clay bricks and/or cement blocks and/or lightweight blocks and/or precast panels and/or reinforced concrete and/or dry partition wall.

4. Roof

Pitch Roof : Metal roofing sheet with insulation.

RC Flat Roof : Reinforced concrete roof with waterproofing system and insulation.

5. Ceiling [For all Units]

a.) Living, Dining, Master Bedroom, Bedrooms, Kitchenette, Balcony and PES Skim coat with emulsion paint generally and/or plaster board ceiling with emulsion paint (where applicable).

b.) Master Bathroom, Other Bathrooms, Kitchen and WC Plaster board ceiling with emulsion paint.

6. Finishes

a.) Wall [For all Units]

i.) Living, Dining, Master Bedroom, Bedrooms, Study, Balcony and PES Plaster and/or skim coat with emulsion paint.

ii.) Master Bathroom and Other Bathrooms Marble and/or Ceramic and/or Homogeneous tiles laid up to false ceiling height and on exposed surface only.

iii.) WC and Kitchen/Kitchenette Ceramic and/or Homogeneous tiles laid up to false ceiling height and on exposed surface only and/or plaster and/or skim coat with emulsion paint.

iv.) Private Spa Pool Mosaic and/or Ceramic and/or Homogeneous tiles.

b.) Floor [For all Units]

i.) Master Bathroom, Other Bathrooms, Living, Dining and Kitchenette Marble.

ii.) Master Bedroom, Bedrooms and Study Timber strip with timber skirting.

iii.) WC, Kitchen, Balcony, PES and Open Roof Terrace Ceramic and/or Homogeneous tiles.

iv.) Air con ledges Cement and sand screed.

v.) Private Spa Pool Mosaic and/or Ceramic and/or Homogeneous tiles.

7. Windows

a.) Powder Coated Aluminum framed windows with minimum 6mm thick clear and/or tinted and/or obscured glass, where applicable.

b.) All windows are either sliding or side hung or top hung or bottom hung or louvred or any combination of the mentioned.

8. Doors

a.) For all units

i.) Main Entrance Approved fire-rated timber door.

ii.) Master Bedroom, Bedrooms, Study, Master Bathroom and Other Bathrooms Hollow-core timber door.

iii.) WC PVC door and/or glass door.

iv.) Kitchen Timber door with clear glass panel.

v.) Balcony, PES and Open Roof Terrace Aluminum framed glass door.

vi.) Household Shelter Approved metal door

b.) Good quality locksets and ironmongery to be provided.

9. Sanitary Fittings (For all units)

a.) Master Bathroom and Other Bathrooms -1 shower cubicle. -1 vanity basin with mixer tap. -1 water closet. -1 mirror. -1 toilet roll holder. -1 towel rail.

b.) WC -1 wash basin. -1 water closet. -1 mirror. -1 toilet roll holder. -1 bib tap.

c.) Kitchen -1 kitchen sink c/w tap.

10. Electrical Installation

a.) Electrical wiring will be concealed conduits where applicable.

Where there is a false ceiling, the electrical wiring will be in surface mounted conduit in the ceiling space.

b.) The routing of services within the units shall be at the sole discretion of the Architect and Engineers.

c.) Sufficient light points and electrical socket outlets are provided.

11. TV / Cable Services / Telephone points

a.) Cable-Readiness to comply with authorities requirements.

b.) Sufficient TV points and telephone points are provided.

12. Lightning Protection

Lightning Protection System shall be provided in accordance with the current edition of Singapore Code of Practice.

13. Painting

a.) Internal Walls : Emulsion Paint. b.) External Walls : Texture coating weather shield paint and/or other approved exterior paint to external plastered surface.

14. Waterproofing

Waterproofing to floors of Kitchen, Master Bathroom, Other Bathrooms, WC, Balcony, Private Spa Pool, PES, Open Roof Terrace and Reinforced Concrete Flat Roof.

15. Basement and 1st Storey Car Park / Driveway

a.) Concrete finished with floor hardener and/or granite and/or heavy duty homogeneous tiles and/or perforated concrete slab and/or interlocking pavers.

16. Recreational Facilities

a.) Guard House

b.) Drop Off Point.

c.) Lap Pool.

d.) Wading Pool.

e.) Sun Deck.

f.) Aqua Spa Seat.

g.) Hydro Therapy Pool.

h.) Tea Party Pavilion.

i.) Gymnasium.

j.) Fitness Station.

- k.) Rejuvenation Courtyard.
- l.) Children's Playground.
- m.) The Rabbit Hole.
- n.) Tropical Crater Slide.
- o.) Sculptural BBQ Gazebo.
- p.) Lily Pond.
- q.) Brook Walk.
- r.) The Club House.
- s.) Herb and Spice Garden.

17. Additional Items

- a.) Wardrobes Wardrobes to all bedrooms.
- b.) Kitchen cabinets
 - i.) Built-in high and low level kitchen cabinets with solid surface counter top, sink, cooker hood, microwave, fridge and washer/dryer.
 - ii.) Conventional oven for Type C1,C1(P),C1(PP), C2, C2(P), C2(P1), C3, C4, PH6, PH7, PH8, PH9, PH10, PH11, PH12.
 - iii.) Electric hob for Type A1, A1(P), A2, A2(P), A3, A3(P), A3(P1), A4, A4(P), A5, A5(P) and PH1, PH2, PH3 PH4, PH5.
- Gas hob for Type B1, B1(P), B1(PP), B2, B3, B3(P), B4, B4(P), B4(P1), BS, BS(P), C1, C1(P), C1(PP), C2, C2(P) C2(P1), C3, C4 and PH6, PH7, PH8, PH9, PH10, PH11, PH12.
- Wine Cellar for Type A3(P), A3(P1), C1, C1(P), C1(PP), C2, C2(P), C2(P1), C3, C4 and PH10, PH11, PH12.
- c.) Air-conditioning to Living, Dining, Master Bedroom, Bedroom and Study.
- d.) Hot water supply to Master Bathroom, Other Bathrooms and Kitchen.
- e.) Audio Intercom to each residential units.
- f.) Mechanical Ventilation for Master Bath at Type A3, A3(P), A3(P1), A4, A4(P), A5, A5(P) and for Bathroom at Type PH3, PH4, PH5.
- g.) Auto car barrier access system.

Notes:

1. The brand and model of all equipments and appliances supplied will be subject to Architect's selection, market availability and the sole discretion of the Vendor.
2. Layout/location of wardrobes, kitchen cabinets, fan coil units, fittings and electrical appliances, electrical points, door swing and plaster ceiling board are subject to Architect's sole discretion and final design.
3. The air-conditioning system has to be maintained and cleaned on a regular basis by the purchaser. That includes the cleaning of filters and clearing of condensate pipes to ensure good working condition of the system.
4. The Purchaser is liable to pay annual fee, subscription fee and such other fees to the Starhub Cable Vision Ltd (SCV) and/or internet service providers (ISP) or any other relevant party or any other relevant authorities. The Vendor is not responsible to make arrangements with any of the said parties for the service connection for their respective subscription channels and/or internet access.
5. Where warranties are given by the manufacturers and/or contractors and/or suppliers of any of the equipment and/or appliances installed by the Vendor at the Unit, the Vendor shall assign to the Purchaser such warranties at the time when possession of the Unit is delivered to the Purchaser.
6. Timber strips are natural materials containing veins/grains and tonal differences. Thus it is not possible to achieve total consistency of colour and grain in their selection and installation. Timber strips are also subject to thermal expansion and contraction beyond the control of the Vendor and the builder.
7. Selected tile sizes and tile surface flatness cannot be perfect, and subject to acceptable range described in Singapore Standards SS483:2000.
8. Marble and granite are natural stone materials containing veins with tonality differences. There will be colour and markings caused by their complex mineral composition and incorporated impurities. While such materials can be pre-selected before installation, this non-conformity in the marble or granite hence cannot be totally avoided. Granite tiles are pre-polished before laying and care has been taken for their installation. However granite, being a much harder material than marble cannot be re-polished after installation. Hence some differences may be felt at the joints. The tonality and pattern of the marble or granite selected and installed shall be subject to availability.
9. Glass is a manufactured material that is not 100% pure. Nickel sulphide impurities may cause spontaneous glass breakage, which may occur in all glass by all manufacturers. The Purchaser is recommended to take up home insurance covering glass breakage to cover this possible event.
10. To ensure good working condition of the mechanical ventilation system for the exhaust system, the system has to be maintained by the Purchaser on a regular basis.
11. The Purchaser will not erect or construct or cause to be erected or constructed, enclosure, shelter, roof, cover or any structure whatsoever over the open roof terraces and other roof terrace within the Housing Project.
12. All units are provided with communal refuse hopper at the common area. There is no refuse chute within the unit.
13. While every reasonable care has been taken in preparing this brochure and the plans attached, the developer and its agents cannot be held responsible for any inaccuracies therein. All statements, specifications and plans are believed to be correct but not to be regarded as statements or representations of fact. Visual representations, illustrations, photographs and renderings are intended to portray only impressions of the development and cannot be regarded as representation of facts. Photographs or images contained in this brochure do not necessary represent as built standard specifications. All information and specifications are current at the time of press and are subject to change as may be required and cannot form part of an offer or contract. All plans are subject to amendment approved by the building authorities. Floor area are approximate measurements and subject to final survey. The choice of brand and model of fittings, equipments, installation and appliances supplied shall be at the sole discretion of the Vendor.
14. For cyclical maintenance work to be carried out to the building façade, owners shall allow access to the maintenance team.

RECENT PROJECTS



THREE BALMORAL - Balmoral Road (Apartment)



POETS VILLAS - Tagore Ave (Strata Housing)



HERTFORD COLLECTION - Hertford Road (Apartment)



BALCON EAST - Upper East Coast Road (Apartment)

Over the last 60 years since its incorporation in the 1950s, Tong Eng Brothers and its group of companies have prided themselves on developing distinctive buildings that are a harmonious blend of form and functionality.

Through the 1960s till today, the group has owned and developed hundreds of acres of land, encompassing office, retail, landed housing and apartment projects.

The Tong Eng Group continues to blend creative planning and understated elegance while adopting new concepts and technology in developing buildings with enduring value. With each project, careful attention is paid to every detail, from redefining spaces to ensure the optimum layout, as well as providing only the most impeccable finishing and quality.

Future projects in the pipeline are a luxury residential development on a 57,005 sq ft freehold site at 16 Balmoral Road & a 118 unit freehold strata housing development at Ang Mo Kio.



6226-6333
www.tongeng.com.sg

Tong Eng Group of Companies 101 Cecil Street #26-01/07 Tong Eng Building S(069533)



